**Instruction
Manual**



**Models 4370□□
μR1800 Recorder**

IM 4H3B1-01E

INTRODUCTION

Thank you for purchasing the μ R1800 Recorder.
To take full advantage of all functions of the μ R1800 Industrial Recorder, and to operate this instrument correctly and efficiently, please read this Instruction Manual carefully before use.

- NOTES**
- YOKOGAWA reserves the right to change this manual at any time without notice.
 - If you find any ambiguities or errors in this manual, please inform YOKOGAWA.
 - This manual is the eighth edition, July 1998.
- Previous editions were released as follows:

November '92	first edition
May '93	second edition
October '93	third edition
April '94	fourth edition
October '95	fifth edition
April '96	sixth edition
May '98	seventh edition
July '98	eighth edition

SAFETY PRECAUTIONS

- The μ R1800 is a Component Type instrument and should be mounted on a panel.
- The μ R1800(except portable type) is a Safety Class I instrument (provided with terminal for protective earthing).
- The μ R1800(except portable type) is an EN55011(EMI standard) Group 1, Class A instrument.
- This instrument complies with Installation Category II.

The following general safety precautions must be observed during all phases of operation, service, and repair of this instrument. Failure to comply with these precautions or with specific WARNINGS given elsewhere in this manual violates safety standards of design, manufacture, and intended use of the instrument.

YOKOGAWA Electric Corporation assumes no liability for the customer's failure to comply with these requirements.

General definitions of safety symbols used on equipment and in manuals



Explanation: To avoid injury, death of personnel or damage to the instrument, the operator must refer to an explanation in the instruction manual.



Protective grounding terminal: To protect against electrical shock in case of a fault. This symbol indicates that the terminal must be connected to ground before operation of equipment.



High temperature: To avoid injury caused by hot surface, don't touch the heatsink.

WARNING

A **WARNING** sign denotes a hazard. It calls attention to a procedure, practice, condition or the like, which, if not correctly performed or adhered to, could result in injury or death of personnel.

CAUTION

A **CAUTION** sign denotes a hazard. It calls attention to a procedure, practice, condition or the like, which, if not correctly performed or adhered to, could result in damage to or destruction of part of the product.

WARNING

Power Supply

Ensure the source voltage matches the voltage of the power supply before turning on the power.

Protective Grounding

Make sure to connect the protective grounding to prevent an electric shock before turning on the power.

Necessity of Protective Grounding

Never cut off the internal or external protective grounding wire or disconnect the wiring of protective grounding terminal. Doing so poses a potential shock hazard.

Defect of Protective Grounding and Fuse

Do not operate the instrument when protective grounding or fuse might be defective.

Fuse

To prevent a fire, make sure to use the fuse with specified standard (current, voltage, type). Before replacing the fuse, turn off the power and disconnect the power source. Do not use a different fuse or short-circuit the fuse holder.

Do not Operate in an Explosive Atmosphere

Do not operate the instrument in the presence of flammable liquids or vapors. Operation of any electrical instrument in such an environment constitutes a safety hazard.







Never Touch the Interior of the Instrument

Inside this instrument there are areas of high voltage; therefore, never touch the interior if the power supply is connected. This instrument has an internal changeable system; however, internal inspection and adjustments should be done by qualified personnel only.

External Connection

To ground securely, connect the protective grounding before connecting to measurement or control unit.

CONTENTS

	INTRODUCTION	1
	SAFETY PRECAUTIONS	2
	HOW TO USE THIS MANUAL	6
Chapter 1	FEATURES AND FUNCTIONS	
	1.1 Features	1 - 1
	1.2 Summary of Functions	1 - 2
Chapter 2	BEFORE OPERATION	
	2.1 Handling Precautions	2 - 1
	2.2 Checking the Contents	2 - 2
	2.2.1 Checking Accessories and Appearance	2 - 2
	2.2.2 Removing Packings	2 - 3
	2.2.3 Checking Model Code	2 - 3
Chapter 3	INSTALLATION	
	3.1 Installation Site/Mounting	3 - 1
	3.1.1 Installation Site	3 - 1
	3.1.2 Mounting	3 - 2
	3.1.3 Dimensional Drawings	3 - 3
	 3.2 Wiring	3 - 4
	3.2.1 Rear Panel Arrangement	3 - 4
	 3.2.2 Power Supply Wiring	3 - 5
	 3.2.3 Input Wiring	3 - 6
	 3.2.4 Alarm Output Wiring	3 - 9
	 3.2.5 FAIL/Chart End Wiring	3 - 10
	 3.2.6 Remote Control Wiring	3 - 11
Chapter 4	COMPONENT NAMES AND FUNCTIONS	
	4.1 Front Panel	4 - 2
	4.2 Display	4 - 4
Chapter 5	DAILY OPERATION	
	5.1 How to Switch the Power ON/OFF	5 - 1
	5.2 How to Install (& Replace) Chart, Pens, Ribbon Cassette and Battery	5 - 2
	5.2.1 How to Load (& Replace) the Chart	5 - 2
	5.2.2 How to Install (& Replace) Pens and Ribbon Cassette	5 - 4
	5.2.3 How to Replace the Battery	5 - 6
	5.3 Basic Operation (Operation Mode)	5 - 7
	5.3.1 How to Start/Stop the Recording	5 - 7
	5.3.2 How to Feed the Chart	5 - 7
	5.3.3 How to Get a Manual Printout	5 - 7
	5.3.4 How to Get a List Printout	5 - 8
	5.3.5 How to Get a SET UP List Printout	5 - 10
	5.3.6 How to Get a Message Printout	5 - 12
	5.3.7 How to Acknowledge an Alarm	5 - 13
	5.3.8 How to Select the Display	5 - 14
	5.3.9 How to Cope with FAIL/Chart End	5 - 16
	5.4 How to Use the Key-lock	5 - 17
Chapter 6	HOW TO ENTER SETTINGS	
	6.1 Explanation of Modes	6 - 1
	6.2 Concept of Setting Parameters	6 - 2
	6.3 Flow Charts	6 - 3
	6.3.1 Flow Chart of Operation Mode	6 - 3
	6.3.2 Flow Chart of SET Mode	6 - 4
	6.3.3 Flow Chart of SET UP Mode	6 - 5
	6.4 Setting Parameters in SET Mode	6 - 6
	6.5 List of Initial Setting Values	6 - 7
Chapter 7	BASIC SETTINGS	
	7.1 How to Set Input Range and Recording Span	7 - 1
	7.1.1 SKIP Setting	7 - 2
	7.1.2 Voltage Measurement Setting (VOLT Setting)	7 - 3
	7.1.3 Thermocouple and Resistance Temperature Detector Setting (TC, RTD Setting)	7 - 4
	7.1.4 Digital Input Setting (DI Setting)	7 - 5
	7.1.5 Difference Computation Setting (DELTA Setting)	7 - 6

	7.1.6 Scale Setting (SCL Setting)	7 - 7
	7.1.7 Setting to Obtain Square Root (SQRT Setting)	7 - 8
	7.2 How to Set Alarms	7 - 10
	7.3 How to Assign Units	7 - 12
	7.4 How to Set the Chart Speed	7 - 13
	7.5 How to Set the Clock	7 - 14
	7.6 How to Copy Channel Settings to Another Channel	7 - 15
	7.7 How to Set the Remote RJC (For /N5 Model)	7 - 16
Chapter 8	AUXILIARY SETTINGS (AUX)	
	8.1 Settings for Analog Recording	8 - 1
	8.1.1 How to Adjust the Trend Recording Format	8 - 2
	8.1.2 How to Set Zone Recording	8 - 3
	8.1.3 How to Set Partial Expanded Recording	8 - 4
	8.2 Settings for Digital Printing	8 - 6
	8.2.1 How to Select the Periodic Printout ON/OFF	8 - 6
	8.2.2 How to Set a Tag	8 - 8
	8.2.3 How to Set Messages	8 - 9
	8.3 How to Set the Chart Speed Used When Change-on-alarm or Remote Control is Selected	8 - 10
Chapter 9	CHANGING INITIAL SETTINGS	
	These settings are entered during manufacturing and seldom need to be changed.	
	9.1 How to Change Initial Settings for the Alarm Function	9 - 1
	9.1.1 How to Select the Reflash Function ON/OFF	9 - 2
	9.1.2 How to Select the Output Relay to be of AND/OR Type	9 - 3
	9.1.3 How to Select the Output Relay to be Energizing/De-energizing on Alarm	9 - 4
	9.1.4 How to Select the Alarm Output Relay to be of HOLD/NON-HOLD Type	9 - 5
	9.1.5 How to Select the Alarm Indicator to be of HOLD/NON-HOLD Type	9 - 6
	9.1.6 How to Set the Sampling Interval for Rate-of-change Alarms	9 - 7
	9.1.7 How to Select Alarm Hysteresis ON/OFF	9 - 8
	9.2 How to Change Initial Settings for the Input	9 - 9
	9.2.1 How to Set the A/D Integration Time	9 - 9
	9.2.2 How to Set Upscale/Downscale TC Burnout	9 - 10
	9.2.3 How to Set Internal or External RJC	9 - 11
	9.2.4 How to Select the Input Filter (Pen Model)	9 - 12
	9.2.5 How to Select a Moving Average (Dot Model)	9 - 13
	9.3 How to Change Initial Settings for Analog Recording	9 - 14
	9.3.1 How to Select Pen Offset Compensation ON/OFF (Pen Model)	9 - 14
	9.3.2 How to Assign Different Colors to Channels (Dot Model)	9 - 15
	9.4 How to Change Initial Settings for Digital Printouts	9 - 16
	9.4.1 How to Select Channel Numbers or Tag Printout	9 - 16
	9.4.2 How to Select Scales Printout ON/OFF	9 - 16
	9.4.3 How to Select the New Chart Speed Printout ON/OFF	9 - 17
	9.4.4 How to Select the Record Start Time Printout ON/OFF	9 - 17
	9.4.5 How to Select Alarm Settings and Alarm Printout	9 - 18
	9.4.6 How to Select to Trigger the Periodic Printout	9 - 18
	9.5 How to Select the Type of Bargraph	9 - 20
	9.6 How to Change the Temperature Unit (for USA)	9 - 21
	9.7 How to Initialize Settings	9 - 21
	9.8 How to Change Initial Settings for the REMOTE Option	9 - 22
	9.9 How to Select to Trigger the Recording to Start/Stop	9 - 23
	9.10 How to Change Key-lock Settings	9 - 24
Chapter 10	GENERAL SPECIFICATIONS	
Chapter 11	MAINTENANCE	
	⚠ 11.1 Periodic Maintenance	11 - 1
	11.2 Fuse Replacement	11 - 2
	11.3 Pen Adjustment (Pen Model)	11 - 3
	11.4 Printer Carriage Adjustment (Dot Model)	11 - 4
	11.5 Calibration	11 - 5
	11.6 Cleaning the Plotter Carriage Shaft (Pen Model)	11 - 7
	11.7 Lubrication (Dot Model)	11 - 7
Chapter 12	TROUBLESHOOTING	
	12.1 Error Message Table	12 - 1
	12.2 Troubleshooting Flow Chart	12 - 2

HOW TO USE THIS MANUAL

This manual describes the standard functions, operation procedures and some of the optional functions of the pen model and dot printing model of the μ R1800 recorder.

To use this manual in the most efficient way, please refer to the following table. In this table the aim of the user is broken down into five broad categories. Please check which are applicable to you and refer to the corresponding chapters.

Purchase & Installation	First Time Setting	Daily Operation	Changing Settings	Maintenance & Troubleshooting	Chapters
●	●	●	●	●	Safety Precautions
○	○		○		1 Features and Functions
●					2 Before Operation
●					3 Installation
	●	●	●	○	4 Component Names and Functions
	○	●	○		5 Daily Operation
	●		●		6 How to Enter Settings
	●		●		7 Basic Settings
	○		○		8 Auxiliary Settings (AUX)
	○		○		9 Changing Initial Settings
○	○		○	○	10 General Specifications
				●	11 Maintenance
	○		○	●	12 Troubleshooting

● : necessary to read ○ : optional to read

For operation procedures of options, which are not described in this manual, refer to specific option manuals.

Chapter 1 FEATURES AND FUNCTIONS

This chapter describes the main features and functions of the μ R1800 recorder. The μ R1800 is equipped with all the functions which can be expected in a modern recorder, whereas its functions also reflect the latest user requirements.

1.1 Features

The μ R1800 recorder is a precision measuring instrument that is equipped with many outstanding features:

Compact sized, high reliability: Its compact size (depth 220mm) allows you to install the μ R1800 where only a limited space is available. In case of the pen model, a contact-free potentiometer and a brushless-DC servomotor contribute to its high reliability. In case of the dot printing model, high reliability is obtained by the use of high break down voltage solid-state relays.

Universal inputs: Inputs like DC-voltage, Thermocouple (TC), Resistance Temperature Detector (RTD), and Digital Input (contact) can all be conveniently used. There is no need to change any dials; the type of input can be set using the keyboard.

Easy interactive setting: The setting procedure has been made very easy, by using only panel keys. The μ R1800 asks you to select the desired settings, without the need for remembering difficult setting-codes.

Large informative operator display: The large sized, VFD, display shows the measured data (including the engineering units) or clock, and bargraph at the same time. There are two types of bargraph available: percentage-display, and center-zero display. Because of its 1%-resolution, the bargraph displays very accurately.

Continuous pen recording for up to four channels (pen model only): Depending on your μ R1800 model type, the μ R1800 can measure up to four channels simultaneously. This allows you to decrease the number of recorders you require.

Universal power supply (except for /P1 model): The μ R1800 accepts 90 to 250VAC (except 132 to 180VAC), and 50/60Hz without any problems, or need to turn switches. Therefore the μ R1800 is compatible with a wide variety of power supplies.

High performance: The sampling speed of the μ R1800 pen model is high at 125 ms, whereas the recording cycle of the μ R1800 dot printing model is 6 ch./10 seconds, or 12ch./15sec., 18ch./20sec. or 24ch./30sec. depending on the model. The μ R1800 is equipped with many functions. Special functions can be ordered as an option. Furthermore, its power consumption is low (4pen model; 30VA under normal operation conditions).

Easy maintenance: Because of the use of many contact-free parts, the need for maintenance has been decreased. The μ R1800 is designed in modules, which decreases the time needed for maintenance extensively.

Closed case: The closed case of the μ R1800 allows it to be used in many environments. The front door is in accordance with DIN 40050-IP54.

Computer interface and memory card: If equipped with this option, the μ R1800 can store and retrieve measured data as well as setting data, using an IC memory card or directly from your PC. The available interface is RS-422-A.

Based on international safety standards: The μ R1800 (except portable type) is based on international safety standards, such as the IEC 348.

1.2 Summary of Functions

This paragraph describes a summary of the main functions, together with a recording example.

RECORDING

- Trend: records in a way that the dots do not overlap (dot model only)
- Zone: records on different bands (zones) for individual channels
- Partial: expands part of the recording range for detailed examination
- POC: Pen Offset Compensation: removes the time-axis offset between pens (pen model only)

PRINTOUT

- Channel printout: contains channel No. besides analog recording (dot model only)
- List printout: contains date, time, chart speed (1 & 2), channel No. or tag, range, span values, scale values, partial values and contents of messages (for example, see 5.3.4)
- Manual printout: contains date and time, channel No., type of alarm, latest measured values, units (for all channels)
- Alarm printout: contains channel or tag No., type of alarm, level, mark (Δ for occurrence, ∇ for recover; in case of the dot model, red and blue respectively) and alarm ON/OFF-time
- Periodic printout: contains date & time, tag or channel No., POC ON mark (\times ; for pen model only), unit, scale markings (may not be printed while alarm occurs), chart speed, measured values and recording color (for pen model) and time tick (for dot model)
- Message printout: contains time and message
- Recording start printout: contains time when recording starts
- Chart speed change: contains time and new chart speed
- SET UP List printout: contains initial settings concerning analog recording, digital printing, alarms, burnout, RJC and options (for example, see 5.3.5)

NOTE The alarm, channel (for dot model), periodic, message, recording start and chart speed change printout depend on the chart speed. The size of the characters varies depending on the chart speed.

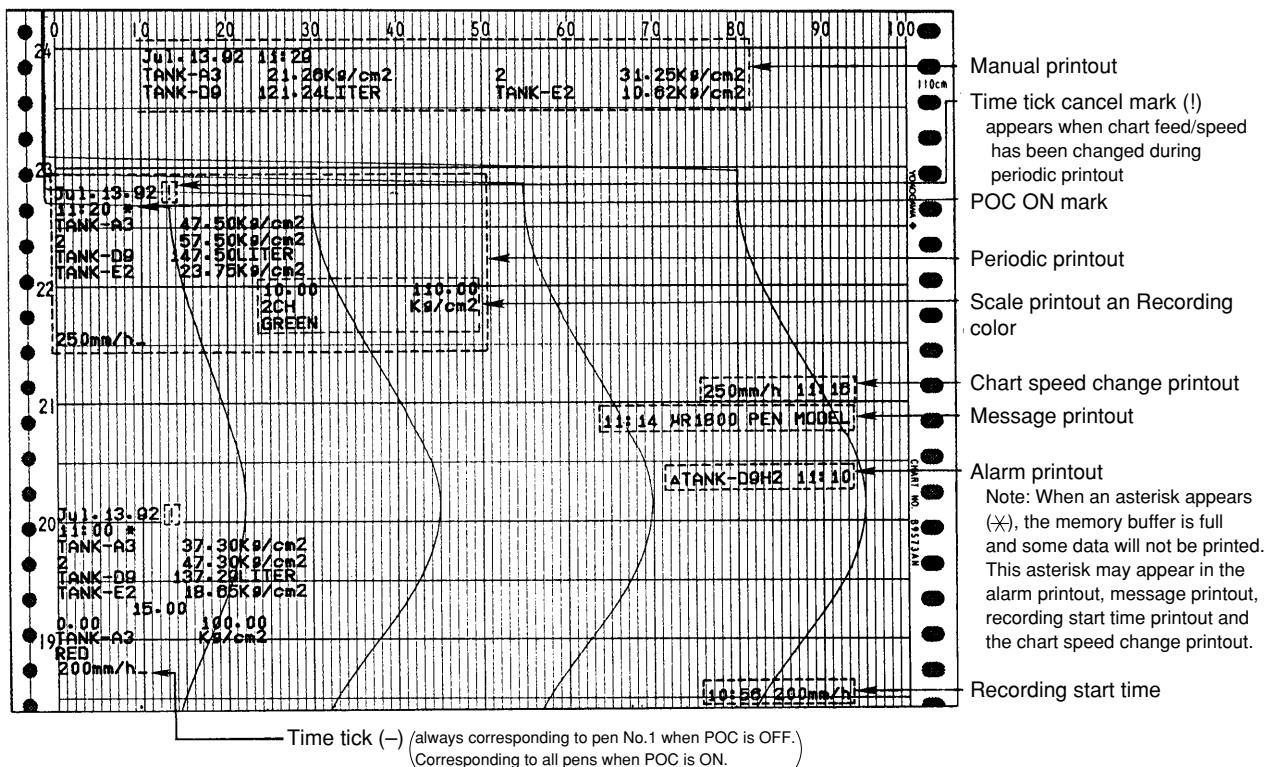

Figure 1.1 Recording Example for Pen Model

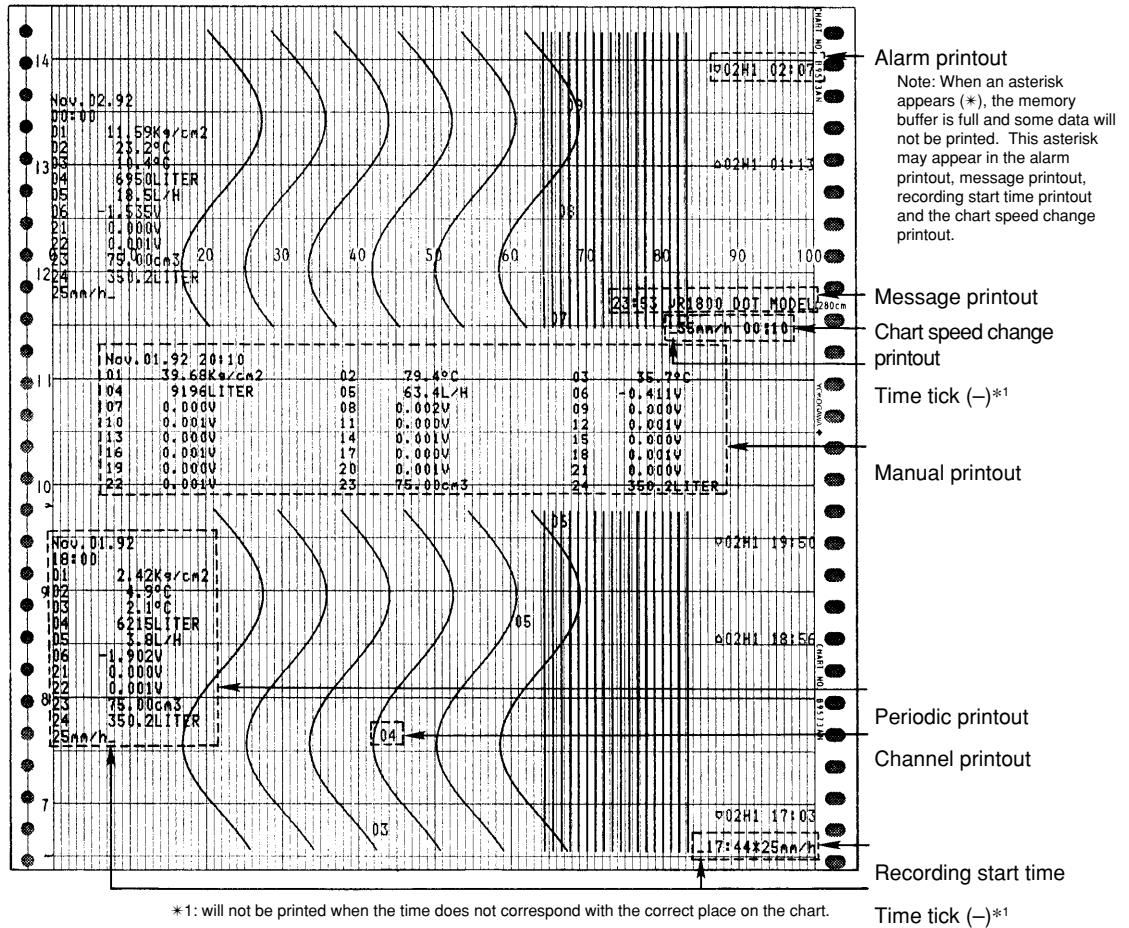

Figure 1.2 Recording Example for Dot Model

ALARM

- Type of alarms: H: high limit
- L: low limit
- h: high difference limit
- l: low difference limit
- R: rate-of-change limit on increasing signal
- r: rate-of-change limit on decreasing signal

Hysteresis: hysteresis value as a % of span which can be 0% or approx. 0.5%

Alarm output relay: when alarm occurs, the relay will be activated (optional)

Reflash: monitors repeating alarm occurrences among a group of alarms sharing the same output relay (optional)

FAIL/Chart-end output: output relay is activated when chart reaches its end and/or when failure of equipment occurs (optional)

INPUT

- Type of inputs: TC: Thermocouple
- RTD: Resistance Temperature Detector
- DC-voltage
- DC-current: using optional external shunt resistor
- DI: Digital Input (contact)

Burnout: when TC-wire is broken, pens will move to left or right side

Filter: (signal damping) selects the time constant of signal damping (for pen model)

Moving average: selects the number of samples for moving average (for dot model)

DISPLAY

- Left-referenced bargraph: measured data are displayed as a %, on a 0 to 100% scale
- Center-zero bargraph: center of the recording span is reference and deviation is displayed as a bargraph
 - Clock: year/month/day and hours/minutes/seconds
- Measured data: AUTO: all channels will be shown alternately
MAN: a specified channel only will be shown
- Alarm: channel No., type of alarm (display), channel No. (underneath bargraph, for dot model)
- Status indicators: RCD: illuminated when recording is in progress
POC: illuminated when POC is being used (for pen model)
SET: illuminated when in SET Mode
AUTO: illuminated when AUTO display is used
MAN: illuminated when Manual display is used
CLK: illuminated when Clock display is used
ALM: illuminated/flashing when alarm occurs
CHT: illuminated when approx. 2cm are left till chart end (option)
BAT: illuminated/flashing when battery needs to be replaced

CALCULATION

- Difference calc (DELT): takes the difference between the measured values of two channels
- Linear scaling (SCL): sets different scale (and unit) to a specific range
- Square root (SQRT): takes the square root of measured data
- MATH: calculates basic arithmetic computations, SQRT, ABS, LOG, EXP, logical and relational computation (optional)
- TLOG: calculates statistic computation for time axis (optional)

COMPUTER INTERFACE (Optional)

RS-422-A

IC MEMORY CARD (Optional)

Storage and retrieval of setting parameters and measured data

REMOTE CONTROL (Optional)

Message printout, manual printout, periodic printout, recording ON/OFF, chart speed change, TLOG START/STOP, IC memory card trigger.

Chapter 2 **BEFORE OPERATION**

This chapter describes the preparations to be made before you can operate the μ R1800 recorder. To use the μ R1800, it is necessary to read this chapter first.

2.1 Handling Precautions

Cleaning

The μ R1800 contains many plastic parts, like door window and panels. Therefore never attempt to clean the μ R1800 with chemicals like benzene or thinner.

Static electricity

Do not bring any objects charged with static electricity near the signal terminals. This might cause malfunction.

Insecticide sprays, etc.

Do not allow any volatile substances such as insecticides etc. to come in contact with the front door, the operation panel, etc. Do not allow rubber or vinyl to remain in contact with the recorder for long periods.

After use

Ensure that the power switch is turned to the OFF position.

In case of malfunction

Never continue to use the instrument if there are any symptoms of malfunction such as unusual sounds, smell, or smoke coming from the instrument. Immediately disconnect the power supply and stop further use of the instrument. If such abnormal symptoms occur, contact your sales representative or nearest service center.

2.2 Checking the Contents

This μ R1800 was thoroughly inspected before it was shipped from the factory. However, when you receive the μ R1800, check that all accessories are present and in the correct quantities. Also check the external appearance of the μ R1800 to ascertain that no damage has occurred.

2.2.1 Checking Accessories and Appearance

The μ R1800 should be accompanied by the accessories indicated in figure 2.1. Check that all are present in the correct quantities. Also check the external appearance of the μ R1800 to ascertain that no damage has occurred. If you discover any problem concerning the quantity of accessories or external appearance, please contact your sales representative or the nearest service center. Addresses may be found on the back cover of this Instruction Manual.

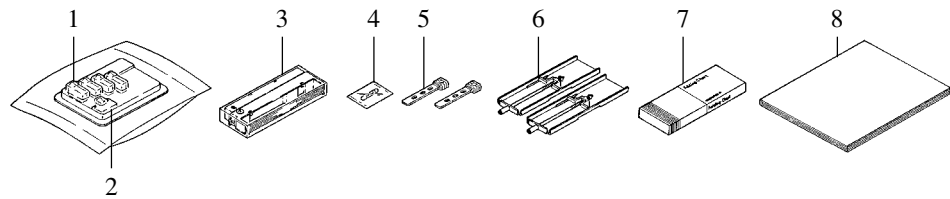

No.	Description	Quantity	Remarks
1.	disposable felt pen (for pen model)		
	• 1 pen model	1	red
	• 2 pen model	2	red, green
	• 3 pen model	3	red, green, blue
	• 4 pen model	4	red, green, blue, violet
2.	plotter pen (for pen model)	1	purple
3.	ribbon cassette (for dot model)	1	
4.	fuse	1	250V 750mA time lag (except for /P1 model)
		1	250V 5A time lag (for /P1 model)
			Recorders with a gray power switch
		1	250V 800mA time lag (except for /P1 model)
		1	250V 5A time lag (for /P1 model)
			Recorders with a white power switch
5.	key	2	key-lock
6.	mounting brackets	2	
7.	Z-fold chart paper	1	approx. 20 meters
8.	Instruction Manual and Quick Reference power cord	1	one each
		1	for portable type

Figure 2.1 Accessories

Table 2.1 Spares

Name	Part Number	Description
Z-fold chart paper	B9573AN	(1 chart/unit), order quantity: 6 units
disposable felt-pen	B9902AM	red (3 pcs./unit), order quantity: 1 unit
disposable felt-pen	B9902AN	green (3 pcs./unit), order quantity: 1 unit
disposable felt-pen	B9902AP	blue (3 pcs./unit), order quantity: 1 unit
disposable felt-pen	B9902AQ	violet (3 pcs./unit), order quantity: 1 unit
plotter pen	B9902AR	(3 pcs./unit), order quantity: 1 unit
ribbon cassette	B9906JA	(1 pc./unit), order quantity: 1 unit
fuse	A1438EF	(4pcs./unit), order quantity : 1 unit
		250V 750mA time lag (except for /P1 model)
	A1102EF	(4pcs./unit), order quantity : 1 unit
		250V 5A time lag (for /P1 model)
		Recorders with a gray power switch
	A1512EF	(4pcs./unit), order quantity : 1 unit
		250V 800mA time lag (except for /P1 model)
	A1513EF	(4pcs./unit), order quantity : 1 unit
		250V 5A time lag (for /P1 model)
		Recorders with a white power switch
mounting brackets	B9900CW	(1 pc./unit), order quantity: 2 units
key (for key-lock)	B9900HZ	(1 pc./unit), order quantity: 2 units
lubricating oil	B9901AZ	(1 pc./unit), order quantity: 1 unit

2.2.2 Removing Packings

The internal assembly is secured in position by packings to safeguard against damages during transit. When you unpack the recorder, remove the packings as follows: Open the μ R1800 front door and swing open the display by grabbing the tabs located at the lower right and left side of the display and pulling these tabs up. See figure 2.2a.

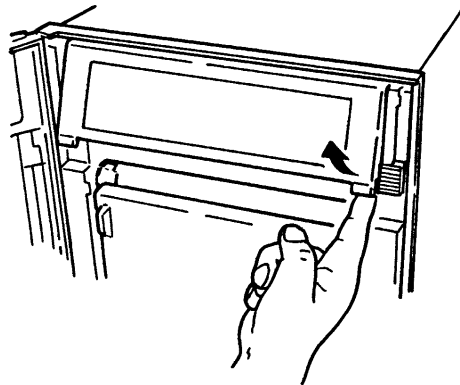

Figure 2.2a Swinging Up the Display

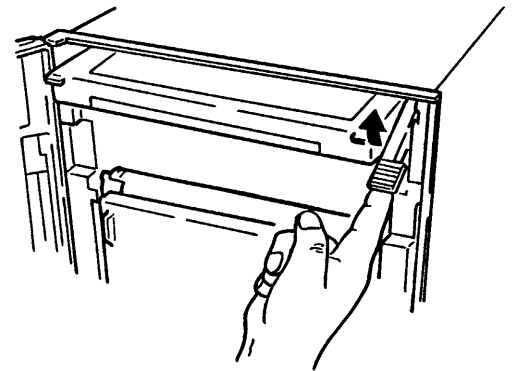

Figure 2.2b Closing the Display

Then remove all the packings as shown in figure 2.3.

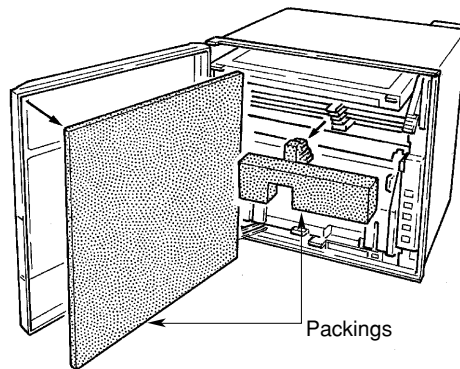

Figure 2.3a Removing Packings in case of Pen Model

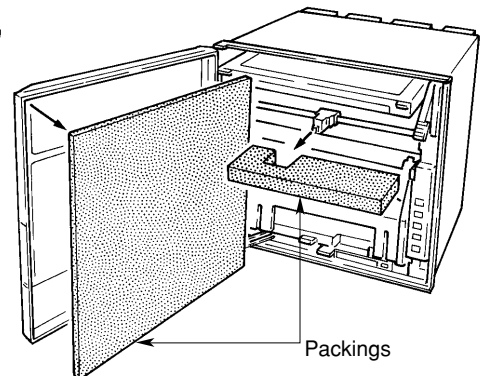

Figure 2.3b Removing Packings in case of Dot Model

After having removed the packings, close the display by pulling the 'release'-handle until this handle is at the same level as the display. Then push the display back into its normal position until the tabs click shut. See figure 2.2b.

2.2.3 Checking Model Code

When you receive your μ R1800, check the information on the nameplate to make sure that it is as specified by your order. If you open the front door and remove the chart cassette, you will find the model code mentioned on the nameplate located as shown in figure 2.4. Please check if model code (MODEL) is correct.

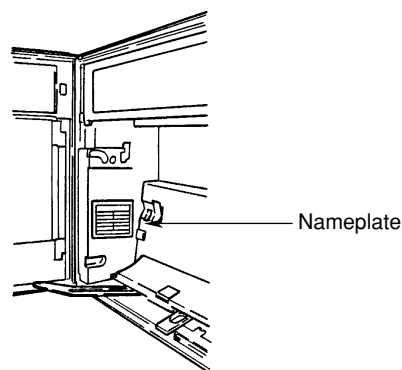

Figure 2.4 Checking Model Code

Chapter 3 **INSTALLATION**

This chapter describes the installation of the μ R1800, like the installation site, the mounting and wiring. To install the μ R1800 properly, it is necessary to read this chapter.

3.1 Installation Site/Mounting

3.1.1 Installation Site

The μ R1800 installation site should be chosen to meet the following conditions as close as possible:

Installation site should be panel-mounted only. The μ R1800 is especially designed for panel mounting.

The μ R1800 should be placed in a well ventilated area.

The μ R1800 will be adversely affected if the unit is exposed to direct sunlight or installed near a heater. Choose a location near room temperature (23°C) with minimal temperature fluctuations.

To expose the μ R1800 to soot, steam, moisture, dust, corrosive gases etc. will adversely affect it.

To use the μ R1800 within strong electro-magnetic fields may cause malfunction. Please avoid installing near electro-magnetic objects.

To install the μ R1800 in a location susceptible to mechanical vibrations will adversely affect the mechanical parts and the quality of recording. Please choose an installation site characterized by minimal mechanical vibrations.

This μ R1800 must be installed horizontally (however, mounting may be inclined up to 30° backwards from vertical).

To use the μ R1800 within domestic establishments and within establishments directly connected to a low voltage power supply network which supplies buildings used for domestic purposes may cause malfunction of other equipments. Please avoid using in domestic environment.

3.1.2 Mounting

- 1 The μ R1800 should be mounted on at least 2mm (and up to 26mm) thick steel panel.
- 2 Insert the μ R1800 into the panel cutout.
- 3 Hold the bottom of the μ R1800 and mount it on the panel using the mounting brackets supplied, as shown in figure 3.1. (If still in place, remove the seals covering the holes for the mounting brackets.)

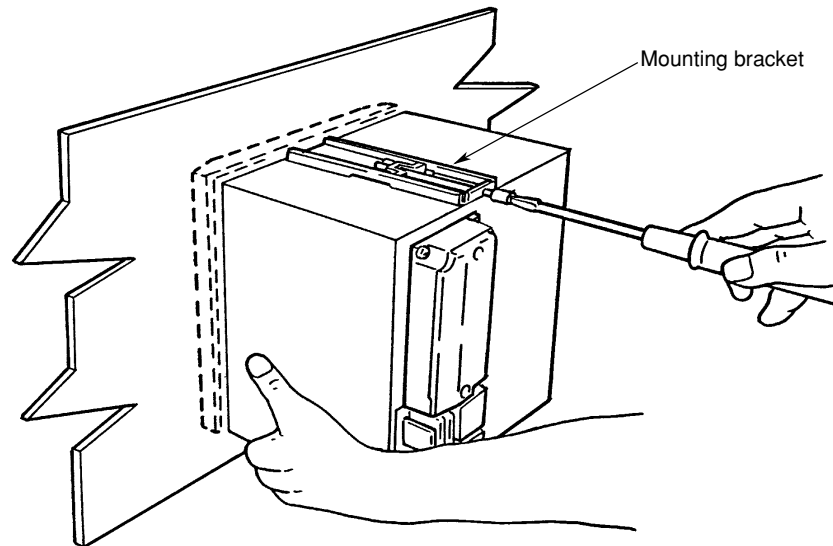

Figure 3.1 Mounting

3.1.3 Dimensional Drawings

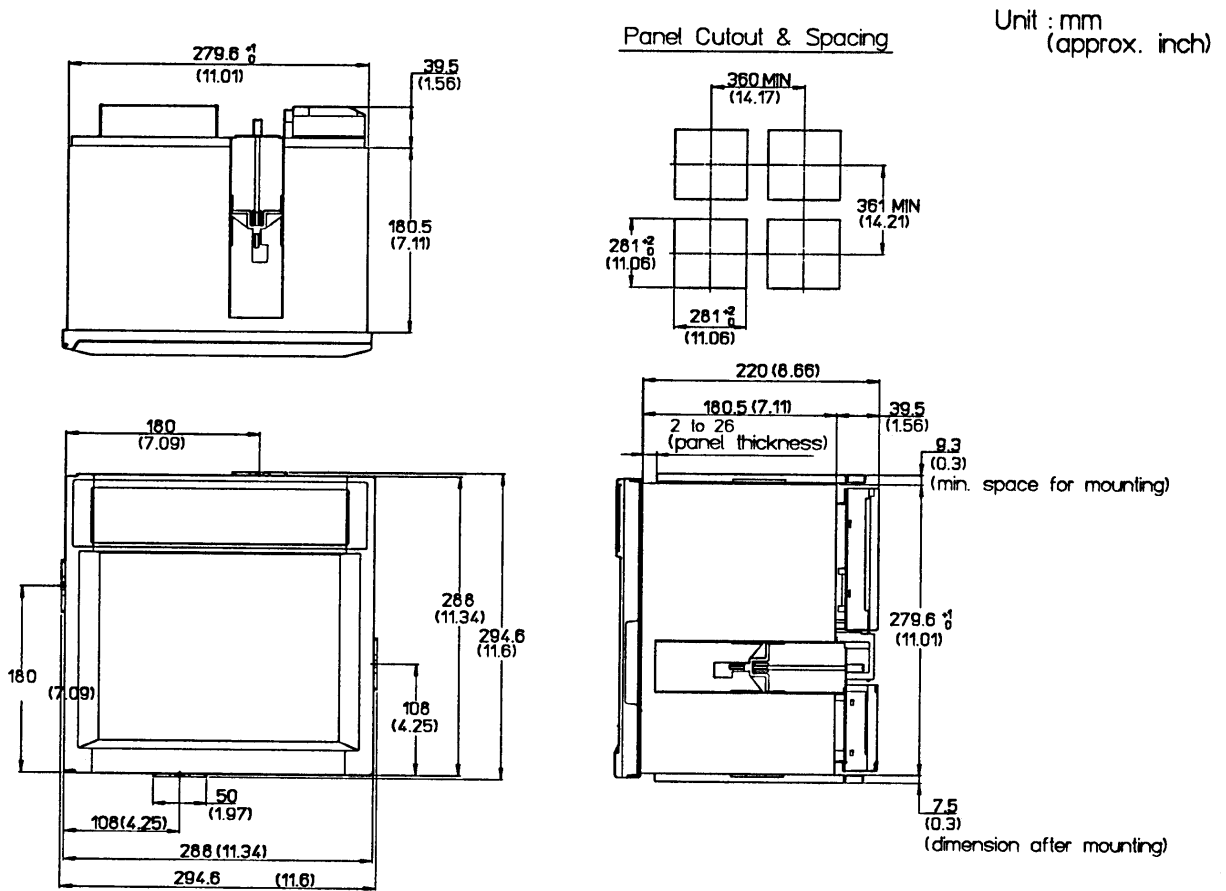

Figure 3.2 Panel Cutout and Spacing (including mounting brackets)

- NOTE**
- The μ R1800 should be mounted by only two brackets, either on the top & bottom of the recorder, or on the left & right side of the recorder.
 - The portable type has different dimensions.

3.2 Wiring

This paragraph describes the wiring at the rear panel.

- 3.2.1 Rear panel arrangement
- 3.2.2 Power supply wiring
- 3.2.3 Input wiring
- 3.2.4 Alarm output wiring
- 3.2.5 FAIL/Chart end output wiring
- 3.2.6 Remote control wiring

CAUTION

Make sure to fasten the wiring at the rear wall of the mounting panel and employ some kind of strain relief between the rear wall and the recorder.

3.2.1 Rear Panel Arrangement

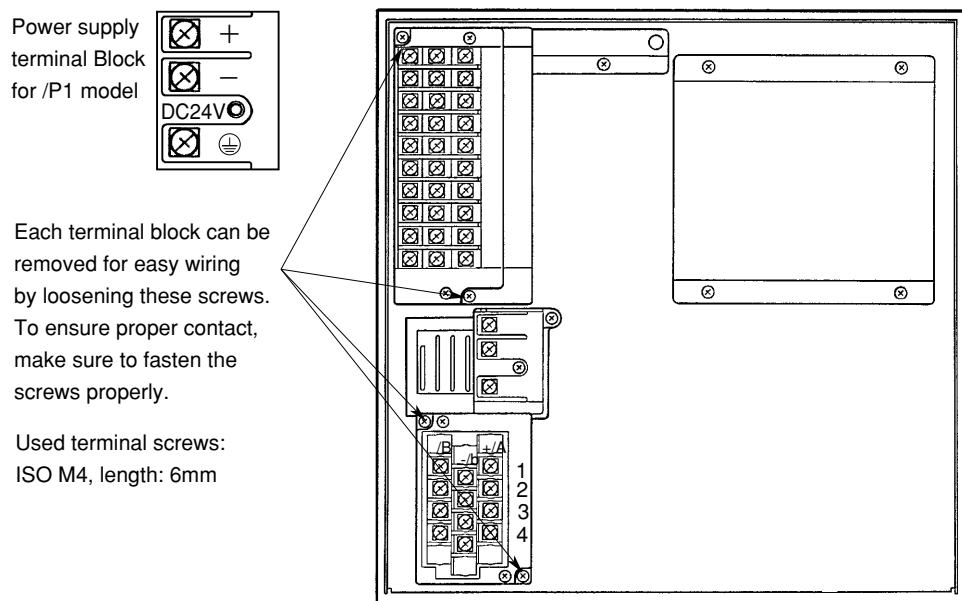

Figure 3.3a Rear Panel Arrangement in case of Pen Model

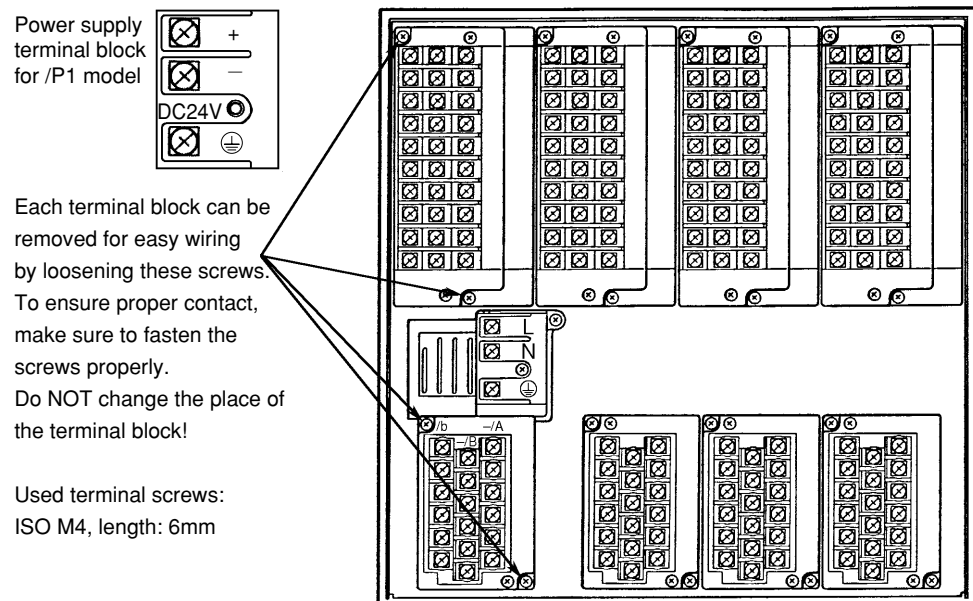

Figure 3.3b Rear Panel Arrangement in case of Dot Model

3.2.2 Power Supply Wiring

- 1 Make sure the power switch is turned OFF and remove the transparent cover at the rear of the μ R1800.
- 2 Connect the power supply wires and the protective ground wire to the power terminals and the ground terminals as shown in figure 3.4.
- 3 Replace the transparent cover.

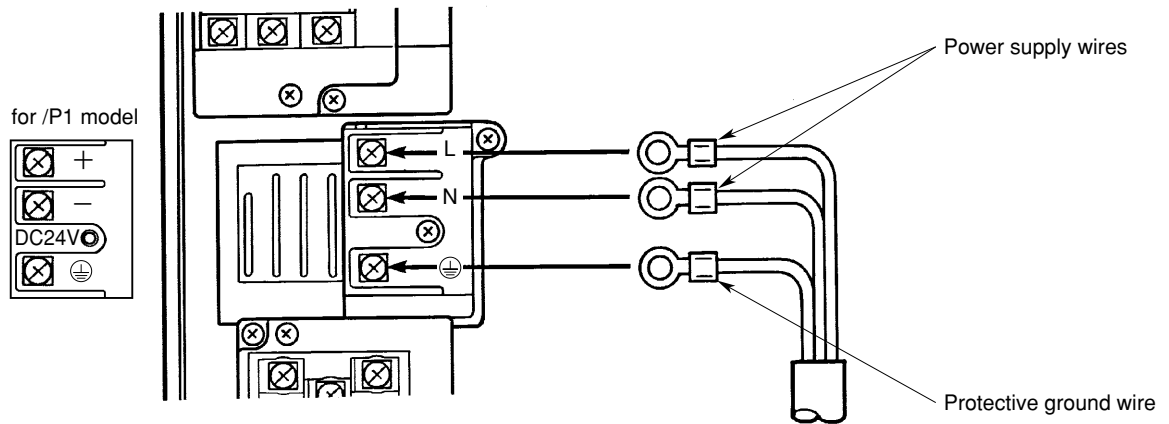

Figure 3.4 Power Supply Wiring

- NOTE**
- Do not apply power supply of 132 to 180VAC. This might affect the measuring accuracy.
 - In case of portable type, plug the female end of power cord into the socket on the rear panel.
 - To prevent an emission of electromagnetic disturbances, separate the power supply wires from the other wires at least 0.1m. Over 0.5m is recommended.

WARNING

To prevent an electric shock, ensure the main power supply is turned OFF and connect the ground terminal using a class 3 resistance of 100 Ω or less. For power and ground wiring termination, use "crimp on" lugs (for 4mm screws) with insulation sleeves (see figure 3.5).

To prevent fire, use 600V PVC insulated wire (AWG18) for power and ground wiring (cross sectional area of 0.83mm² or thicker, anti-galvanic corrosion finish, insulation thickness should be more than 0.8mm, insulation resistance should be more than 50M Ω Km at 20°C, approved EN60 320 (VDE0625), and do not remove the transparent cover.

Make sure to apply a power switch in the power supply cord with the following characteristics:

Others than /P1 model

- rated power current > 1A
- rated rush current > 60A
- fuse(s) of 2A to 15A is (are) necessary.

/P1 model

- rated power current > 3A
- rated rush current > 70A
- fuse(s) of 5A to 15A is (are) necessary.

The power switch and fuse used in the power supply cord should be

- CSA approved (for use in North America)
- VDE approved (for use in Europe).

3.2.3 Input Wiring



- 1 Make sure the power switch is turned OFF and remove the transparent cover at the rear of the μ R1800.
- 2 Connect the input wires to the input terminal.
- 3 Replace the transparent cover.

It is recommended that “crimp on” lugs (for 4mm screws) with insulation sleeves be used for leadwire ends. See figure 3.5.

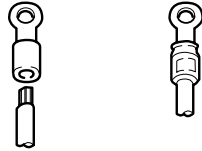

Figure 3.5 “Crimp on” Lugs

In case of clamped input terminals, do not use “crimp on” lugs.

Since the input terminal will be affected by changes in temperature (e.g. because of wind), make sure to replace the transparent cover after wiring.

Even after replacement, take care not to expose the terminals to fans, etc.

Suggestions to minimize noise pickup:

- The measuring circuit wiring should be run as remote as possible from the power and ground wires.
- It is recommended that shielded wires be used to minimize noise pickup from an electrostatic induction source. The shielding wire of the cable should be connected to the μ R1800 ground terminal (only one ground line).
- To minimize noise from an electromagnetic induction source, twist the measuring line cables in short and equal spaces.
- The to be measured object should be free from noise. However, if it isn't, make sure the measuring circuit is isolated and the to be measured object is grounded.

If TC and RJC is used, the temperature of the input terminals should be as stable as possible. Therefore, make sure to use the transparent cover. The thermal capacity of the wiring should be small (recommended $\phi \leq 0.3\text{mm}$).

Refrain from wiring the input parallel. However, if you do, then

- do not use the burnout function
- ground the equipments at the same point
- turning ON/OFF the power might cause malfunction
- RTD cannot be wired parallel.

WARNING

To prevent an electric shock, ensure the main power supply is turned OFF and connect the ground terminal using a class 3 resistance of 100Ω or less.

CAUTION

If you have an input of $\text{DC} \leq 2\text{V}$ or a TC, don't apply an input voltage exceeding $\pm 10\text{VDC}$.

Do not apply a max. common mode voltage more than 250VAC rms (50/60Hz). The recorder and measured values will be adversely affected.

Add following to 'CAUTION'

This instrument complies with Inatallation Category II.

NOTE

To prevent an emission of electromagnetic disturbances, separate the input wires from the other wires at least 0.1m. Over 0.5m is recommended.

Pen Model

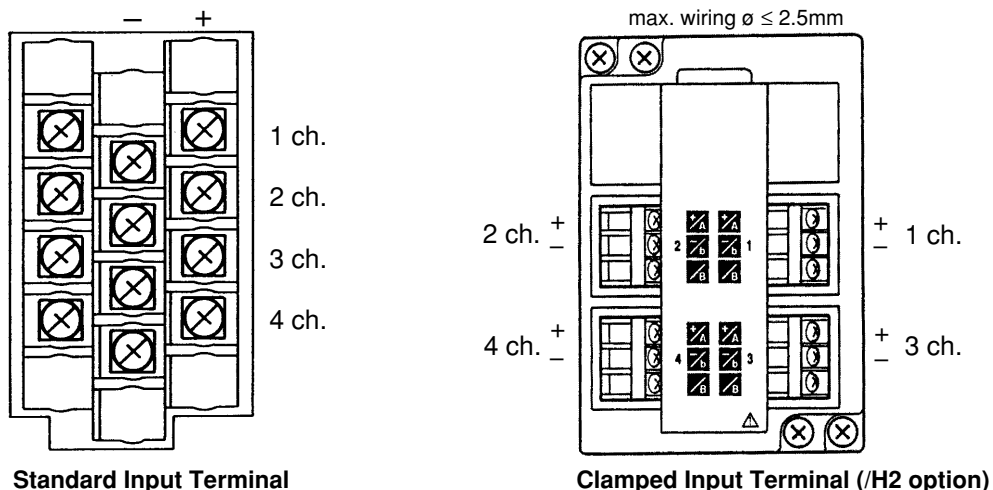

Standard Input Terminal

Clamped Input Terminal (/H2 option)

Figure 3.6 DC V, Thermocouple and Contact Input in case of Pen Model

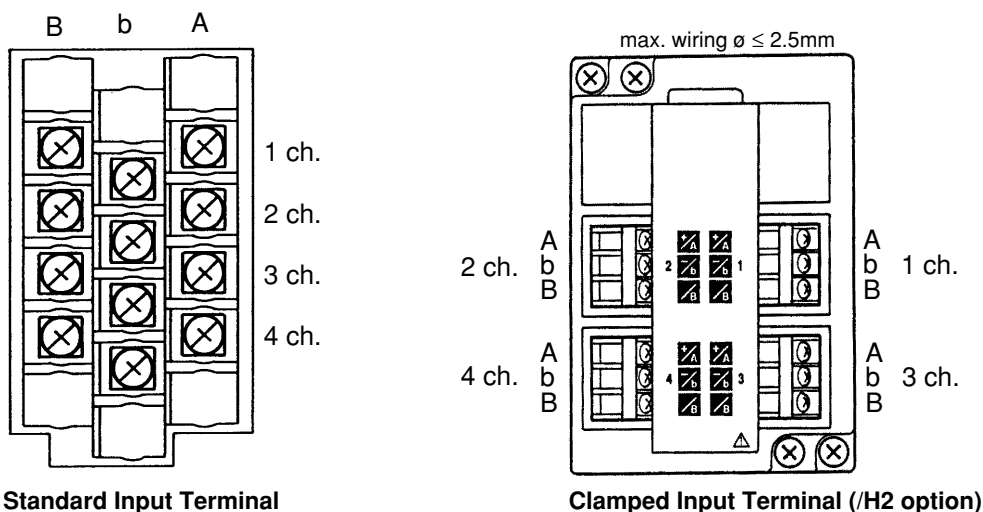

Standard Input Terminal

Clamped Input Terminal (/H2 option)

Figure 3.7 Resistance Temperature Detector Input in case of Pen Model

DC Voltage Input/DI Input (contact)

Thermocouple Input

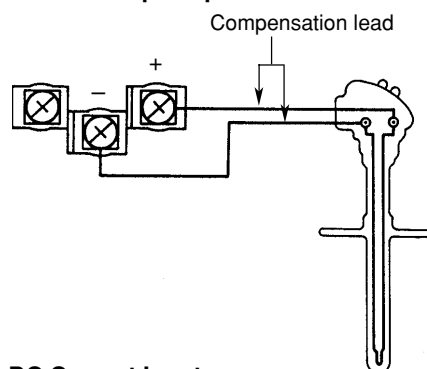
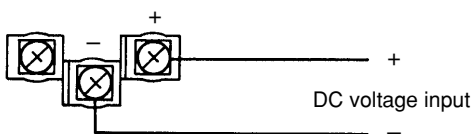

Resistance Temperature Detector Input

DC Current Input

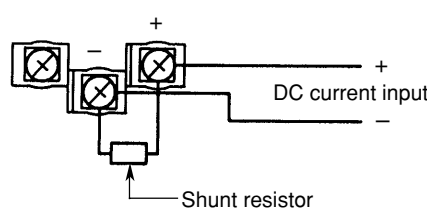
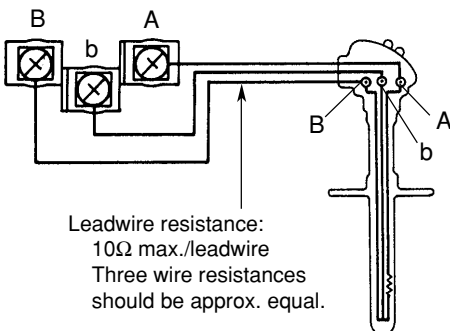

NOTE: For 4 to 20mA input, shunt resistance value should be $250\Omega \pm 0.1\%$.

Figure 3.8 Wiring Input Terminals in case of Pen Model

Dot Printing Model

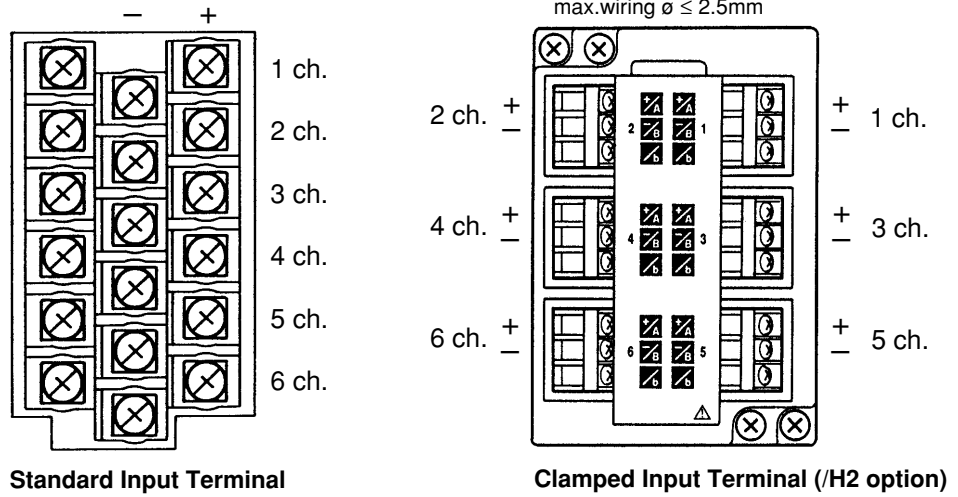

Figure 3.9 DC V, Thermocouple and Contact Input in case of Dot Model

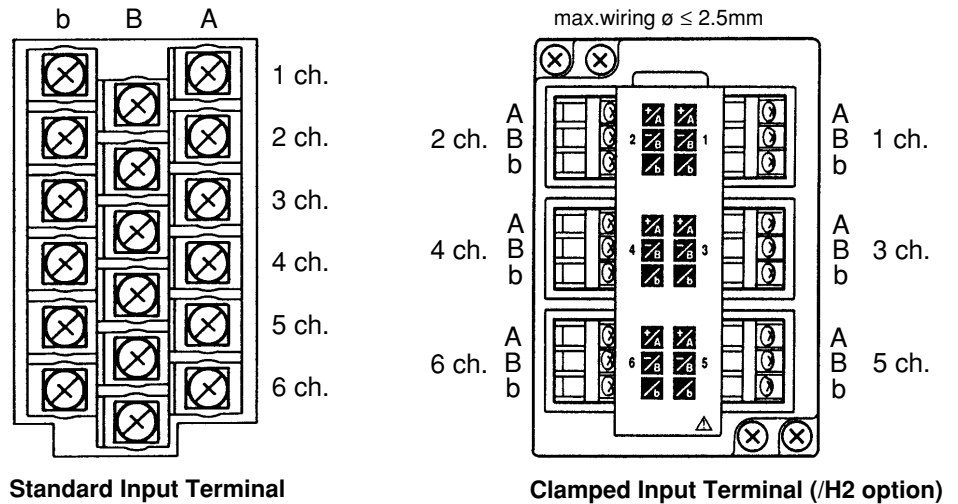
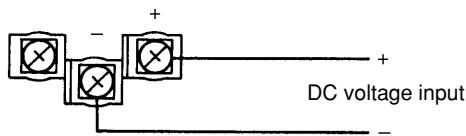
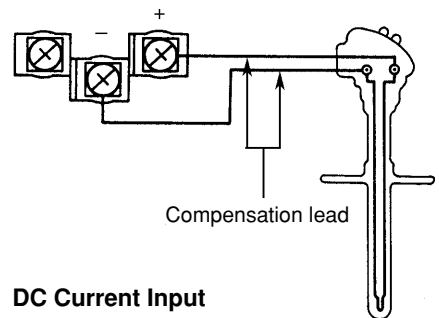

Figure 3.10 Resistance Temperature Detector Input in case of Dot Model

DC Voltage Input/DI Input (contact)



Thermocouple Input



Resistance Temperature Detector Input

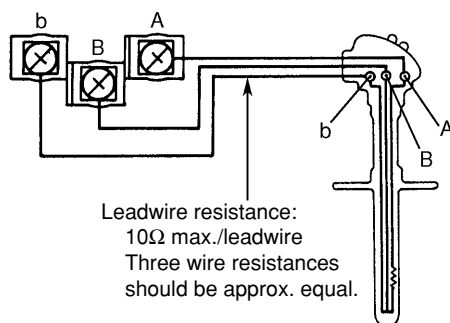

DC Current Input

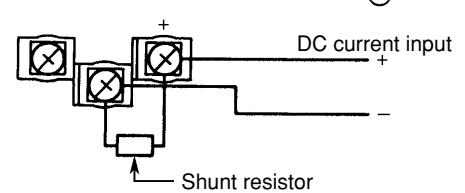

NOTE: For 4 to 20mA input, shunt resistance value should be 250Ω ±0.1%.

NOTE: In case of 3 leg isolated RTD (/N2 option), there is no difference between B and b. However, A and b are designated to be the current line for measurements.

Figure 3.11 Wiring Input Terminals in case of Dot Model

3.2.4 Alarm Output Wiring

- 1 Make sure the power switch is turned OFF and remove the transparent cover at the rear of the μ R1800.
- 2 Connect the alarm output wires to the alarm output terminal. Do NOT change the place of the terminal block!
- 3 Replace the transparent cover.

Depending on your option, your alarm output terminal will be arranged like one of the following:

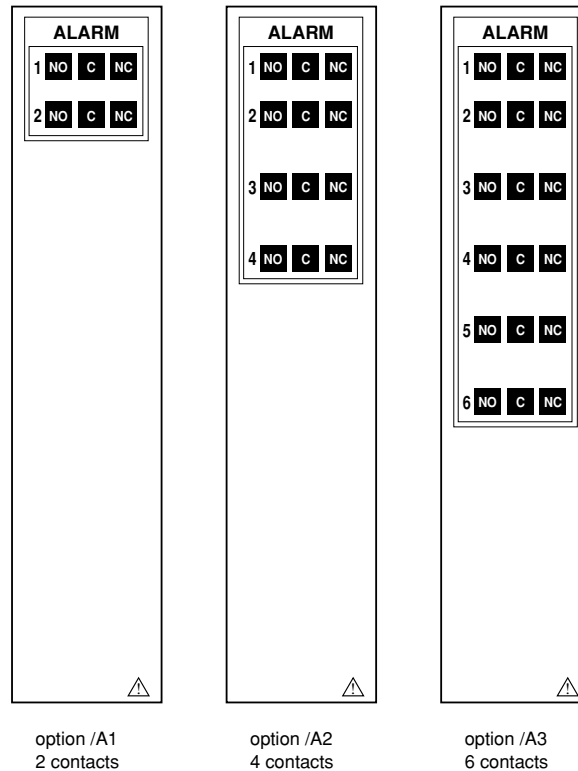

Figure 3.12 Alarm Output Terminals

CHARACTERISTICS:

Output type: relay transfer contact (energize/de-energize type switchable)

Output capacity: 250VAC (50 or 60Hz), 3A
250VDC, 0.1A (resistive load)

Dielectric strength: 1500VAC (50 or 60Hz) for one minute between output terminal and ground terminal

To adjust initial settings, see 9.1.

WARNING

- To prevent an electric shock, ensure the main power supply is turned OFF during wiring and ensure the ground terminal is connected using a class 3 resistance of 100Ω or less.
- Ensure the ground terminal is connected using a class 3 resistance of 100Ω or less.
- Use "crimp-on" lugs with insulation sleeves for all connections if a voltage of more than 30 VAC or 60 VDC is applied to the alarm output or fail/memory end output. Furthermore, use double-insulated wires (withstand voltage performance: more than 2300VAC) for those wires which apply 30 VAC or 60VDC. All other wires can be basic-insulated (withstand voltage performance: more than 1350VAC). To prevent electric shock, do not touch the terminal after wiring and make sure to re-attach the cover.

NOTE To prevent an emission of electromagnetic disturbances, separate the alarm output wires from the power supply and input wires at least 0.1m. Over 0.5m is recommended.

3.2.5 FAIL/Chart End Wiring

- 1 Make sure the power switch is turned OFF and remove the transparent cover at the rear of the μ R1800.
- 2 Connect the FAIL/Chart end output wires to the FAIL/Chart end output terminal.
- 3 Replace the transparent cover.

The FAIL/Chart end terminals (option) are arranged as follows:

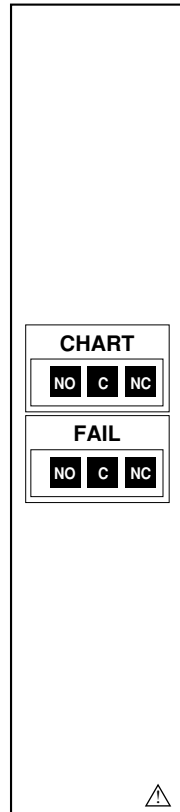

Figure 3.13 FAIL/Chart End Output Terminal

The FAIL/Chart End output relay is of the de-energize type. See 5.3.9 for details.

WARNING

- To prevent an electric shock, ensure the main power supply is turned OFF during wiring and ensure the ground terminal is connected using a class 3 resistance of 100 Ω or less.
- Ensure the ground terminal is connected using a class 3 resistance of 100 Ω or less.
- Use "crimp-on" lugs with insulation sleeves for all connections if a voltage of more than 30 VAC or 60 VDC is applied to the alarm output or fail/memory end output. Furthermore, use doubleinsulated wires (withstand voltage performance: more than 2300VAC) for those wires which apply 30 VAC or 60VDC. All other wires can be basic-insulated (withstand voltage performance: more than 1350VAC). To prevent electric shock, do not touch the terminal after wiring and make sure to re-attach the cover.

NOTE To prevent an emission of electromagnetic disturbances, separate the FAIL/Chart end wires from the power supply and input wires at least 0.1m. Over 0.5m is recommended.

3.2.6 Remote Control Wiring

- 1 Make sure the power switch is turned OFF and remove the transparent cover at the rear of the μ R1800.
- 2 Connect the REMOTE output wires to the REMOTE output terminal. Make sure to connect every terminal with the c(ommon) terminal. Use shielded wires to prevent electromagnetic interference.
- 3 Replace the transparent cover.

The remote control terminal (option) is arranged as follows:

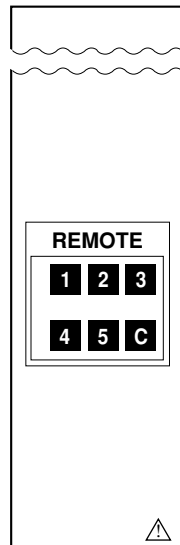

Figure 3.14 Remote Control Terminal

CHARACTERISTICS:

Input signals: dry contact or open-collector (TTL or transistor)

Input types for each function

(1) recording start/stop	level	
(2) change chart speed	level	
(3) start/stop TLOG computation	level	
(4) printout messages	trigger	} 250 ms minimum
(5) get a manual printout	trigger	
(6) get a periodic printout	trigger	
(7) trigger IC Memory Card	trigger	

Input conditions: ON voltage (0.5V maximum) (30mA DC)
 Leakage current in OFF state (0.25mA maximum)
 Signal duration (250 msec minimum)

Input type: Photocoupler isolation (one side common)
 Internal isolated power source (5V \pm 5%)

Dielectric strength: 500VDC between input terminal and ground terminal, 1min.

To adjust initial settings, see 9.8.

WARNING

To prevent an electric shock, ensure the main power supply is turned OFF during wiring and ensure the ground terminal is connected using a class 3 resistance of 100 Ω or less.

The outer conductor must be grounded at the ground terminal.

NOTE

To prevent an emission of electromagnetic disturbances, separate the remote control wires from the power supply and input wires at least 0.1m. Over 0.5m is recommended.

Chapter 4 COMPONENT NAMES AND FUNCTIONS

This chapter describes the names of components, together with a short summary of their functions.

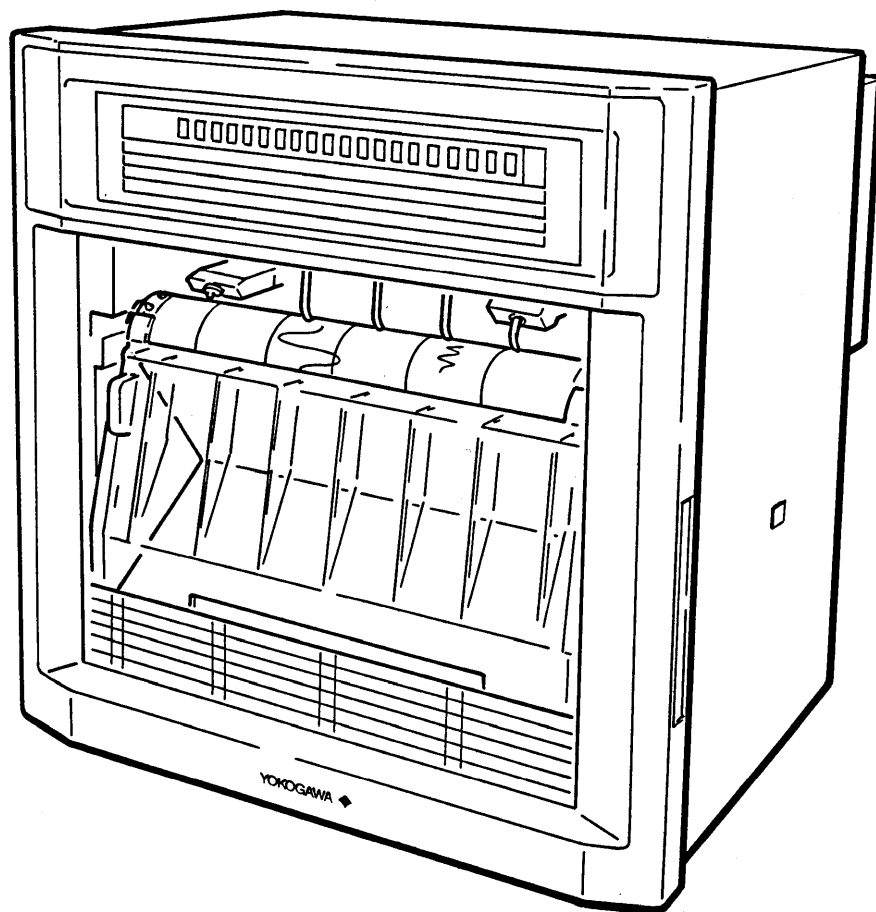

Figure 4.1 External View (pen model)

4.1 Front Panel

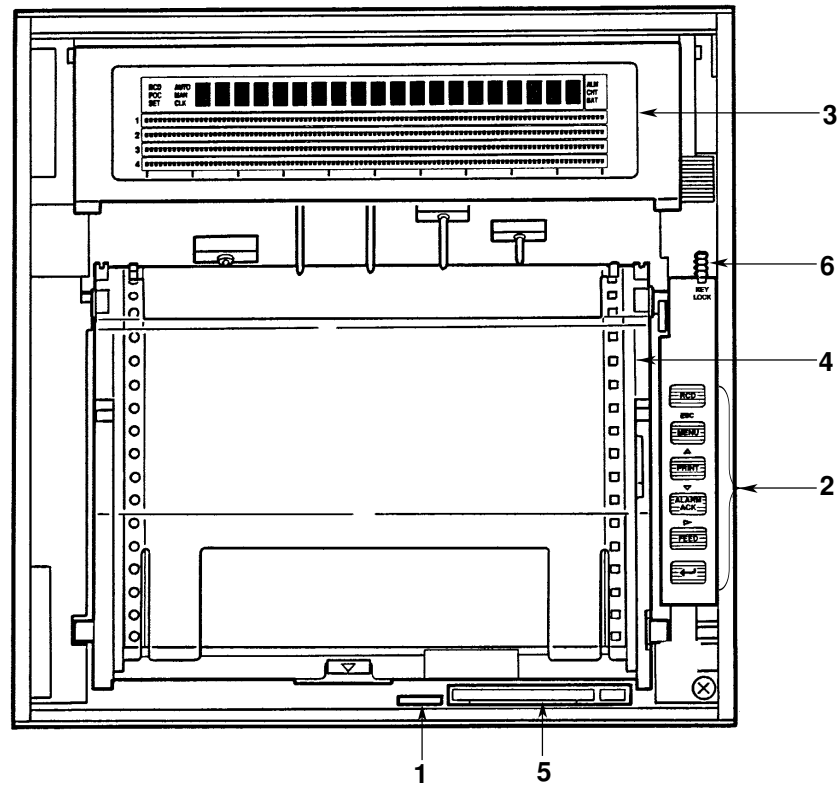

Figure 4.2 Front Panel (4 pen model)

1 Power switch

Pressing this button will result in switching the power ON or OFF.

2 Keyboard

The keyboard consists of six keys:

 **(RCD-key)**

Pressing this key will result in starting or stopping the recording.

 **(Menu-key/Esc-key)**

The MENU function is to select the type of display (see 5.3.8), to start SET UP List printout and message printout (see 5.3.5, 5.3.6) etc., and to switch between Operation and SET modes (see 6.1).

The ESC function is to escape to the previous level in the (setting) flow while entering parameters.

 **(Print-key/Cursor Up-key)**

The PRINT function is used to get a manual printout or list printout printed onto the chart (see 5.3.3, 5.3.4).

The Δ function: The display is designed in an interactive way, which means that it will ask you to enter the necessary data. In case there are several possibilities to choose from (e.g. ON or OFF), use this key to show the next choice.

**(Ack-key/Cursor Down-key)**

The 'ACK'-function is used to acknowledge alarms. Note that this function is only effective if the alarm relay is in the hold-mode (see 5.3.7), and if the indicator status is in the hold-mode (see 5.3.7). When you press this key in case an alarm occurs and the ALM-indicator is flashing, the current alarm situation will be indicated and the relay will be reset.

The ▾ function: The display is designed in an interactive way, which means that it will ask you to enter the necessary data. In case there are several possibilities to choose from (e.g. ON or OFF), use this key to show the previous choice.

**(Feed-key/Move to Next Digit-key)**

The 'FEED'-function feeds the chart paper until this key is released (see also 5.3.2).

The ▷ function moves the cursor to the next digit while setting parameters. Please note that there is not a back-space key provided. For that reason, the cursor moves from the last digit to the first digit again (see 6.2).

**(Ent-key)**

The 'ENT'-function allows you to keep the data you entered during the setting procedure. Pressing 'ENT' results in moving to the next display in the same (setting-) flow. Pressing 'ENT' after the 'SET OK'-display appears, results in starting the same (setting-) flow again.

3 Large sized VFD (Vacuum Fluorescent Display)

The display can show characters, bargraphs, and functions.

The backside of this display also illuminates the chart.

4 Chart and chart cassette

The recorder uses a Z-fold chart, 20 meter in length, with an effective analog trend recording width of 180mm. The chart is stored inside a chart cassette.

5 IC Memory card slot (optional)

IC Memory cards are inserted into this slot for use.

6 Key-lock

The key supplied with the recorder should be removed from the key-hole to lock the recorder. See 5.4. To use the key-lock, see 9.10.

4.2 Display

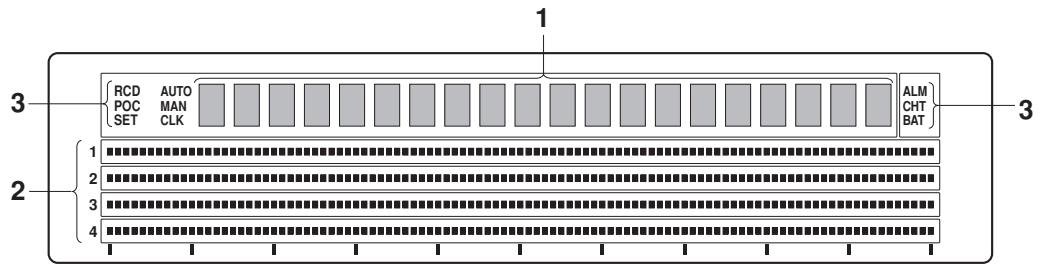

Figure 4.3a Display (4 pen model)

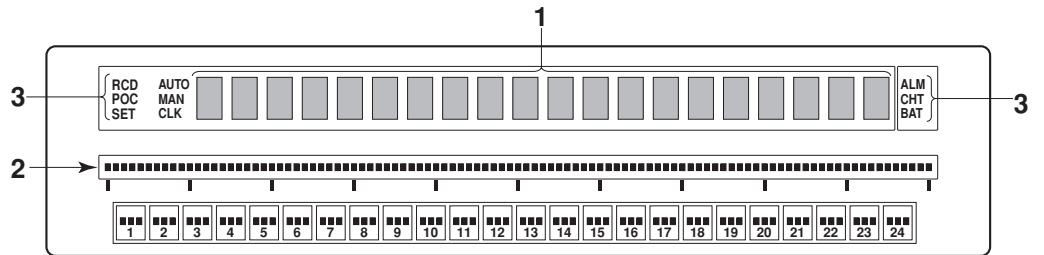

Figure 4.3b Display (dot model)

1 5 × 7 dot matrix (20 characters)

Used for data display, clock display, monitor display and setting display (see also 5.3.8).

Data display: Channel No. or tag, type of alarm, measured data, units

Clock display: (year, month, day) and (hour, minutes, seconds)

Monitor display: Operating conditions of IC Memory Card and TLOG function

Setting display: Every parameter can be set by interactive display.

2 Bargraph

Measured values of each channel will be displayed with 1% resolution (analog display).

The alarm set points will also be displayed. The colors of the bargraph correspond to the colors of the pens. Two ways of display can be selected:

Left-referenced (%) bargraph

Center-zero bargraph

(center of the recording span is reference and the deviation is displayed as a bargraph)

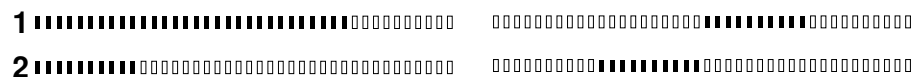

The squares underneath the bargraph show the occurrence of an alarm in the corresponding channel. They illuminate/flash in the same way as the ALM-indicator.

3 Status indicators

RCD: Illuminated when recording is in progress.

POC: Illuminated when Pen Offset Compensation is being used (only for pen model).

SET: Illuminated when you are working in the SET Mode.

AUTO: Illuminated when the AUTO display is used.

MAN: Illuminated when the Manual display is used.

CLK: Illuminated when the Clock display is used.

ALM: This VFD will flash or illuminate when an alarm occurs.

Hold-mode: If the ACK-key is pressed, the flashing will stop and the VFD will illuminate. After the alarm stops, the VFD will turn off. (If the ACK-key is not pressed, the flashing stays even if the alarm recovers, see also 5.3.7).

Non-hold-mode: VFD will illuminate until the alarm recovers (pressing the ACK-key in this case will have no effect, see also 5.3.7).

CHT: Illuminated when there are approx. 2cm left till chart end (option).

BAT: Illuminated when the battery for setting data backup needs to be replaced.

Flashes when the battery of the IC Memory Card needs to be replaced.

Chapter 5 DAILY OPERATION

This chapter describes the daily operation of the μ R1800, excluding settings. Please read this chapter carefully before operation.

5.1 How to Switch the Power ON/OFF

The power switch is located behind the door, at the front side, in the middle of the lower front (see figure 5.1a.). The power is supplied to the instrument when the power switch is in the position as shown in figure 5.1b. The power is OFF when the power switch is in the position as shown in figure 5.1b. The power can be turned ON/OFF by alternately pressing the switch. When you do not use the instrument, please turn 'OFF' the power.

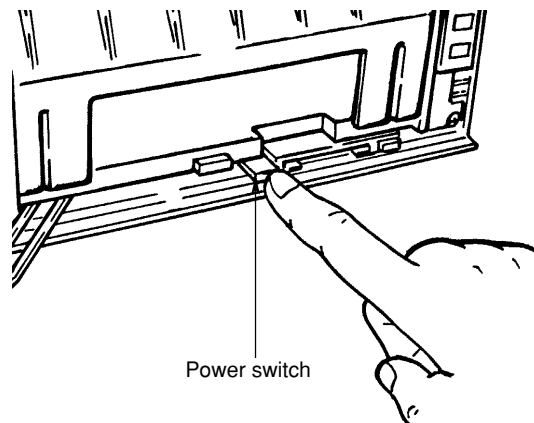

Figure 5.1a

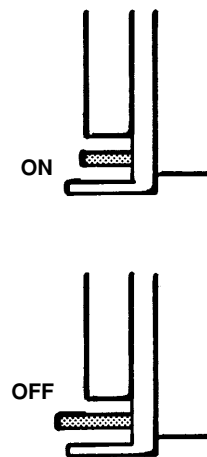

Figure 5.1b

NOTE After turning ON the power, the μ R1800 will first perform a self diagnostic check for several seconds.

CAUTION

The warm-up time is approx. 30 minutes. (However, just after finishing the wiring, it might take longer. Especially if you removed the input terminals during wiring.)

If the input wiring is connected parallel with other equipments, switching the power ON/OFF should not be done.

If error message appears on the display or is printed on the chart, please refer to the Error Message Table at sect.12.1.

5.2 How to Install (& Replace) Chart, Pens, Ribbon Cassette and Battery

5.2.1 How to Load (& Replace) the Chart

- 1 Open the front door of the unit.
- 2 The power can be either 'ON' or 'OFF', but recording should be 'OFF'.
- 3 Fan chart paper thoroughly at both ends before loading.
- 4 While gently pressing the chart paper compartment lock tab, located in the middle at the lower front, in the direction of the arrow, swing and lift the compartment away from the unit (see figure 5.2).

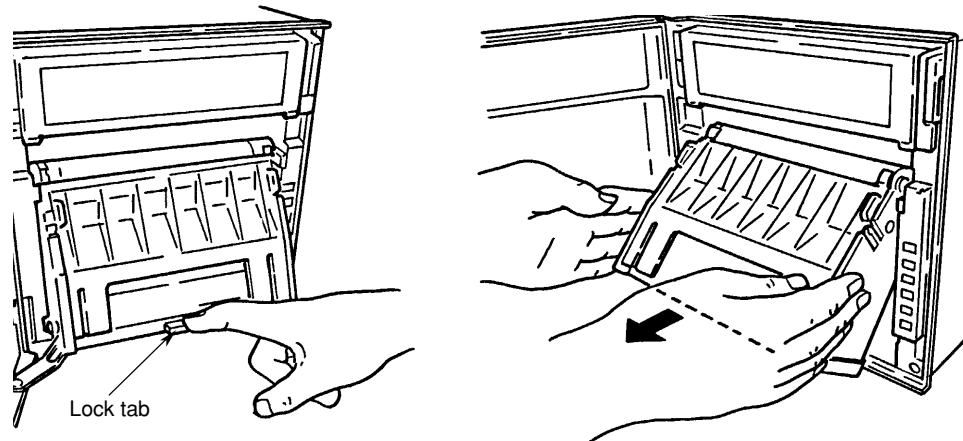

Figure 5.2

- 5 Press the tabs of the chart guide plate at the top rear of the chart compartment and swing the guide plate up (see figure 5.3).
- 6 At the front, pull/swing the front transparent chart guide down and swing the small transparent chart guides open (see figure 5.3).

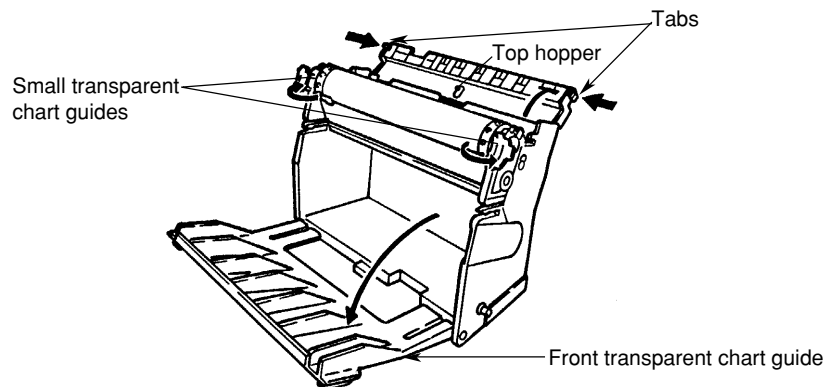

Figure 5.3

- 7 Load the chart paper into the top hopper making sure that the sprocket teeth of the chart drive are properly engaged in the chart paper perforation holes. Take care not to insert the paper backwards (see figure 5.4).

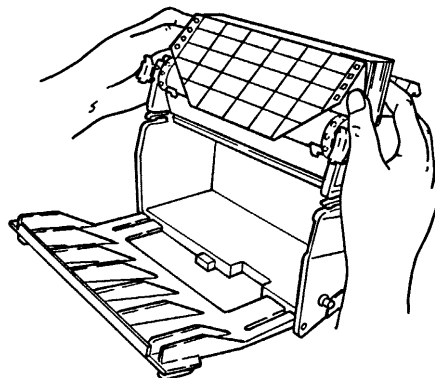

Figure 5.4

- 8 Place the rear chart guide plate back into position. Press the rear chart guide plate down and towards you and load the chart.
- 9 Place the front transparent chart guides back into position (see figure 5.5).

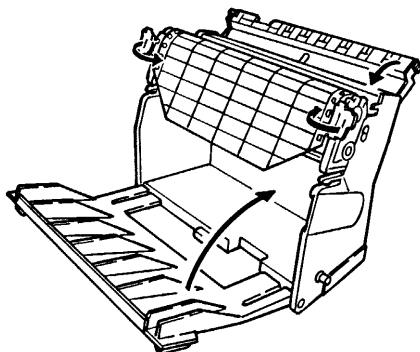

Figure 5.5

- 10 Replace the chart paper compartment back into the unit. Slide the protruding knurls of the chart paper compartment into the cutout grooves located on the support brackets. Push/swing the compartment into the unit until the lock tab clicks shut (see figure 5.6).

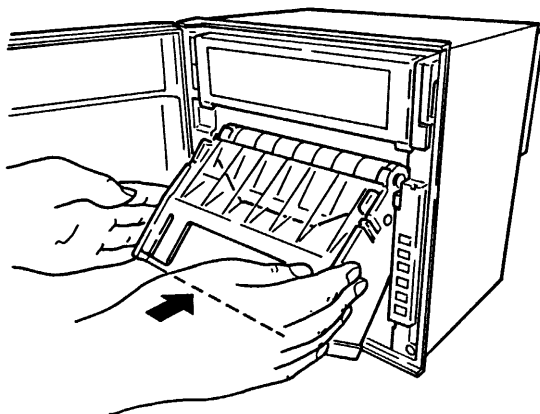

Figure 5.6

- 11 Press the FEED-key (when the power is ON) until 2 leaves of paper are fed (or until the chart is not curled anymore) and confirm that the chart is fed continuously. If not, repeat the procedure from step 4.

NOTE A red band is printed at the end of the chart with the heading 'RENEW CHART' to notify you when it is time to prepare a new chart.

5.2.2 How to Install (& Replace) Pens and Ribbon Cassette

In case of felt-tip pens:

Normal procedure:

- 1 Open the front door and make sure the recording is not in progress (by pressing the RCD-key; power can be either 'ON' or 'OFF').
- 2 Swing up the display by grasping and pulling the tabs located at the lower left and right corner.
- 3 Grasp the protruding part of the felt-tip pen cartridge and gently pull/slide it out of the cartridge holder (see figure 5.7).
- 4 Remove the pen cap before replacing the cartridge with a new one.
Insert a new felt pen cartridge in the pen cartridge holder (see figure 5.7). Start with the smallest pen.

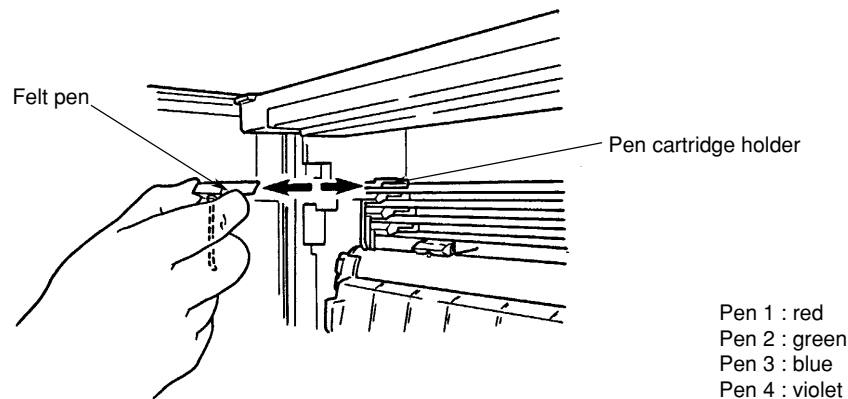

Figure 5.7

- 5 Close the display by pulling the 'release'-handle until this handle is at the same level as the display. Then push the display back into its normal position until the tabs click shut.
- 6 To (re)start the recording, press the RCD-key.

2nd procedure when the pens are located at a place where it is difficult to replace them:

- 1 Open the front door and make sure the recording is not in progress (by pressing the RCD-key; power must be 'ON').
- 2 Press the MENU-key. Use the UP/DOWN-keys to select the display 'MENU=SELECT_FUNCTION'. Press the ENT-key.
- 3 Use the UP/DOWN-keys to select the display 'CHANGE_PEN'. Press the ENT-key.
The pens will move to 55% of the chart, where it is easy to replace them. Note that this will leave a line on the chart.
- 4 Handle as described in 'Normal procedure', steps 2, 3, 4 and 5.
- 5 The display 'PRESS_ENT' will appear. After finishing, press the ENT-key.
- 6 To (re)start the recording, press the RCD-key.

CAUTION

To protect the pens and the internal mechanism, never grasp the pen tip nor apply excessive force to the cartridge holder. Always make sure to remove the pen cap.

In case of plotter pen:

- 1 Open the front door and make sure the recording is not in progress (by pressing the RCD-key; power can be either 'ON' or 'OFF').
- 2 Swing up the display by grasping and pulling the tabs located at the lower left and right corner.
- 3 While grasping the plotter holder, gently slide the plotter out of the holder (see figure 5.8).
- 4 Remove the pen cap and insert a new plotter pen in the holder (see figure 5.8).
If it is difficult to replace the plotter pen, try the 2nd procedure as described above.
- 5 Close the display by pulling the 'release'-handle until this handle is at the same level as the display. Then push the display back into its normal position until the tabs click shut.

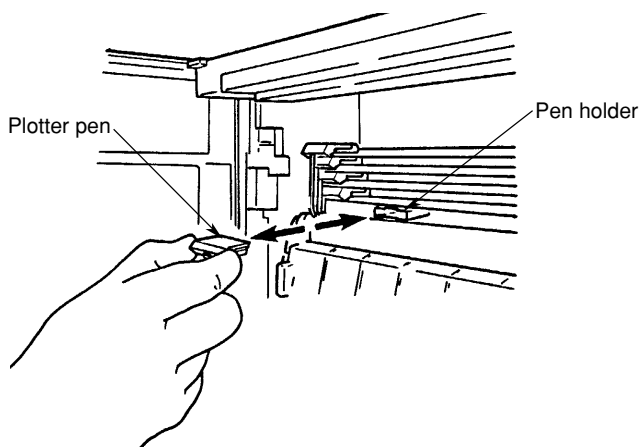

Figure 5.8

In case of the ribbon cassette:

- 1 Open the front door and make sure the power is OFF.
- 2 Swing up the display by grasping and pulling the tabs located at the lower left and right corner.
- 3 Hold the back section of the carriage assembly and move the assembly to the right.
- 4 Press the lock tab to the right and use the lower left part of the cassette as a handle to pull it out of the holder. See figure 5.9.

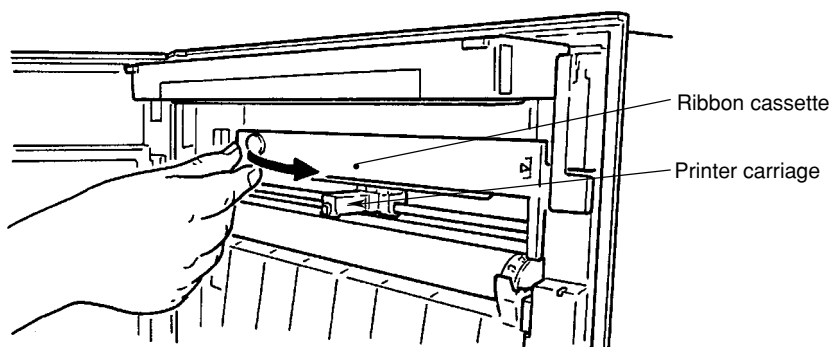

Figure 5.9

- 5 Insert the right side of the new ribbon cassette into the cassette holder.
- 6 Insert the left side of the ribbon cassette into the cassette holder (clicking it into its place). If the ribbon cassette does not click into its place easily, adjust the ribbon feeding knob so that the peg fits the hole.
- 7 If necessary, turn the ribbon feeding knob to stretch/tighten the ribbon.
- 8 Close the display by pulling the 'release'-handle until this handle is at the same level as the display. Then push the display back into its normal position until the tabs click shut.

CAUTION**If the ribbon cassette is not inserted correctly:**

- data may be printed in the wrong color
- ribbon edge is used to print out data, which damages the ribbon.

5.2.3 How to Replace the Battery

The 'BAT' indicator on the VFD-display can either remain illuminated or flash. In case of illumination, the lithium battery needs to be replaced. However, this battery will last for ten years under normal operation conditions. For replacement, please contact the nearest Sales & Service Office. Addresses may be found on the back cover of this manual.

In case of flashing, you have to replace your IC Memory Card battery (option).

In case of replacement, please refer to the IC Memory Card Instruction Manual IM 4H3B1-30E.

WARNING

To avoid injury, never replace the lithium battery yourself.

5.3 Basic Operation (Operation Mode)

5.3.1 How to Start/Stop the Recording

Pressing the RCD-key will cause the recording to start or stop. However, if the Start/Stop function is controlled by remote control, this key will not work.

(For the status of the initial recording settings, see 6.5)

5.3.2 How to Feed the Chart

The paper can be fed by operating the FEED-key. The paper will be fed as long as the FEED-key is pressed.

5.3.3 How to Get a Manual Printout

A manual printout contains:

- date & time
- channel number or tag / type of occurred alarm / latest measured values / units (for all channels)

To get a manual printout, press the PRINT-key, select 'MANUAL_PRINT_START' using the PRINT-key and press the ENT-key.

When the writing of this printout starts, the display will return to the previous one.

When the writing of this printout is finished, the manual printout function is cancelled automatically and the μ R1800 returns to the recording previously in progress.

When you want to cancel the manual printout function while in progress, press the PRINT-key again, and the display 'MANUAL_PRINT_STOP' will appear. Press the ENT-key, and the instrument returns to the recording previously in progress.

During the writing of the manual printout, the analog recording will stop. However, scanning of the input and detection of alarms will still continue. When alarms occur during the manual printout, the printing of these alarms will be done after the analog recording (re)starts.

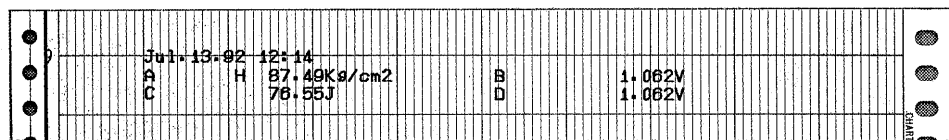

Figure 5.10a Manual Printout Example in case of the Pen Model (two columns appear when tags are set, three columns appear in case of channel numbers)

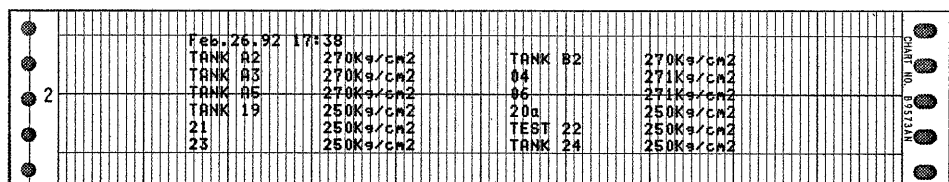

Figure 5.10b Manual Printout Example in case of the Dot Model (two columns appear when tags are set, three columns appear in case of channel numbers)

5.3.4 How to Get a List Printout

A list printout contains:

- date, time and chart speed (1 & 2) and in case of the dot model, the trend recording interval.
- Ch.No. / tag / range / span / scaling values / unit
- type of alarm and values, zone values, partial values, periodic printout ON/OFF
- contents of messages (for all channels).

To get a list printout, press the PRINT-key, select 'LIST_PRINT_START' using the PRINT-key and press the ENT-key.

When the writing of this printout starts, the display will return to the previous one.

When the writing of this printout is finished, this list printout function is cancelled automatically and the μ R1800 returns to the recording previously in progress.

When you want to cancel this list printout function while in progress, press the PRINT-key again, and the display 'LIST_PRINT_STOP' will appear. Press the ENT-key and the μ R1800 returns to the recording previously in progress.

During the writing of the list printout, the analog recording will stop. However, scanning of the input and detection of alarms will still continue. When alarms occur during this printout, the printing of these alarms will be done after the analog recording (re)starts.

14 Jul-13-02 12:22									
CHART SPEED 250mm/h (2)375mm/h									
CH	RANGE		LEFT END	RIGHT END	SCALE	LEFT	RIGHT		
1	2V(SQRT)		-2.000	2.000V	0.00		100.00K	g/cm ²	
2	2V		-2.000	2.000V					
3	2V(SCALE)		-2.000	2.000V	0.00		100.00J		
4	2V		-1.000	1.000V					
CH	ALARM1	RLY	ALARM2	RLY	ALARM3	RLY	ALARM4	RLY	UNIT
1	H	80.00	03	L	0.00	03	H	80.00	03
2	L	10	20	L	30.00	40	L	50.00	01
3	L	10.00					70	80	Y 90
4	L	10.00							Y
CH	TAG No.	DIGITAL	ZONE (mm)	PARTIAL					
1	A	ON	0-90						
2	B	ON	0-90	20%	1.500V				
3	C	ON	0-180						
4	D	ON	0-180						
MESSAGE 1 = μ R1800 PEN MODEL					MESSAGE 2 =				
MESSAGE 3 =					MESSAGE 4 =				
MESSAGE 5 =									

Figure 5.11a List Printout Example in case of Pen Model

22	Nov. 03. 92 20:28									
	CHART SPEED 25mm/h		(2)30mm/h		TREND INTVL FIX(30sec)					
21	CH	RANGE	LEFT END	RIGHT END	SCALE	LEFT	RIGHT			
	01	6V(SCALE)	-5.000V	5.000V	0.0	2000DLITER				
	02	2V(SCALE)	-2.000V	2.000V	0.0	200.0PC				
	03	2V(SCALE)	-2.000V	2.000V	0.0	90.0PC				
	04	2V(SCALE)	-2.000V	2.000V	0.00	100.0DK/cm2				
	05	2V(SCALE)	-2.000V	2.000V	0.0	160.0L/H				
	06	2V	-2.000V	2.000V						
	07	2V	-2.000V	2.000V						
20	08	2V	-2.000V	2.000V						
	09	2V	-2.000V	2.000V						
	10	2V	-2.000V	2.000V						
	11	2V	-2.000V	2.000V						
	12	2V	-2.000V	2.000V						
	13	2V	-2.000V	2.000V						
19	14	2V	-2.000V	2.000V						
	15	2V	-2.000V	2.000V						
	16	2V	-2.000V	2.000V						
	17	2V	-2.000V	2.000V						
	18	2V	-2.000V	2.000V						
	19	2V	-2.000V	2.000V						
0	20	2V	-2.000V	2.000V	70	80	90	100		
18	21	2V	-2.000V	2.000V						
	22	2V	-2.000V	2.000V						
	23	2V(SCALE)	-2.000V	2.000V	0.00	150.00cm3				
	24	2V(SCALE)	-2.000V	2.000V	0.0	700.0LITER				
17	CH	ALARM1	RLY	ALARM2	RLY	ALARM3	RLY	ALARM4	RLY	UNIT
	D2	H	150.0							°C
16	CH	TAG No.	DIGITAL	ZONE (mm)	PARTIAL					
	01		ON	60-110						
	02		ON	46-66						
	03		ON	60-80						
	04		ON	30-50						
	05		ON	90-110						
	06		ON	106-126						
	07		OFF	106-126						
	08		OFF	109-128						
	09		OFF	110-130						
	10		OFF	112-132						
	11		OFF	114-134						
	12		OFF	116-136						
15	13		OFF	118-138						
	14		OFF	120-140						
	15		OFF	122-142						
	16		OFF	124-144						
	17		OFF	126-146						
	18		OFF	128-148						
14	19		OFF	130-150						
	20		OFF	132-152						
	21		ON	134-154						
	22		ON	136-156						
	23		ON	138-158						
	24		ON	140-160						
13	MESSAGE 1 = PRIBOY DOT MODEL					MESSAGE 2 =				
	MESSAGE 3 =					MESSAGE 4 =				
	MESSAGE 5 =									

Figure 5.11b List Printout Example in case of Dot Model

5.3.5 How to Get a SET UP List Printout

A SET UP list printout contains:

- initial settings; analog recording
- initial settings; digital printing
- initial settings; alarms
- initial settings; burnout, RJC and others
- initial settings; options, if installed.

To get the SET UP list printout, proceed as follows:

Press the MENU-key and select the 'MENU=SELECT_FUNCTION' display using the UP/DOWN- keys. Then press the ENT-key. Select the 'PRINT_SETUP_LIST' display using the UP/DOWN-keys. Press the ENT-key, and the printing will start.

When the writing of this printout starts, the display will return to the previous one. When the writing of this printout is finished, this SET UP list printout function is cancelled automatically and the μ R1800 returns to the recording previously in progress.

When you want to cancel this SET UP list printout function while in progress, press the MENU-key again, select the 'MENU=SELECT_FUNCTION' display and press the ENT-key. Then the 'STOP_SETUP_LIST' display will appear and press the ENT-key. The μ R1800 returns to the recording previously in progress.

During the writing of the SET UP list printout, the analog recording will stop. However, scanning of the input and detection of alarms will still continue. When alarms occur during this printout, the printing of these alarms will be done after the analog recording (re)starts.

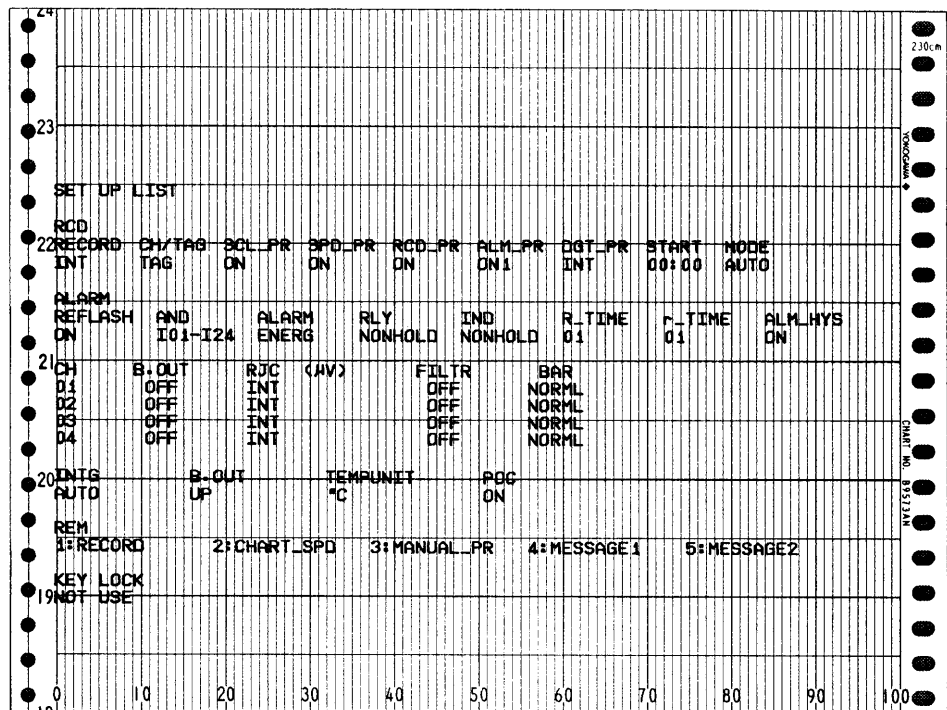

Figure 5.12a SET UP List Printout Example in case of Pen Model

5.3.6 How to Get a Message Printout

The contents of a message must be entered first.

To set or change a message, see 8.2.3.

To get a message printed on the chart, proceed as follows:

Press the MENU-key and select the 'MENU=SELECT_FUNCTION' display using the UP/DOWN-keys. Then press the ENT-key.

Select the 'PRINT_MESSAGE' display using the UP/DOWN-keys. Press the ENT-key, and select which message you want to print out, since up to five messages can be set. Press the ENT-key and the printing will start.

Note that no messages will be printed when the chart speed exceeds 1500 mm/h, in case of the pen model, or 100 mm/h in case of the dot model, or when recording is OFF.

When the writing of this printout starts, the display will return to the previous one.

When the writing of this printout is finished, the μ R1800 returns to the recording previously in progress.

You cannot cancel this printout once started.

Messages can be triggered by the keyboard, as described above, and by remote control (option). When several messages are triggered by remote control in a short time, they will be stored in a buffer memory before printing on the chart. It is possible to clear this buffer, which can be useful for example in case the printing will take too much time. When the buffer is full, this will be indicated by an asterisk (*) in the latest message printout. As a result the next message is lost and will not be printed.

To clear the buffer memory, proceed as follows:

Press the MENU-key.

Select the display 'MENU=SELECT_FUNCTION' using the UP/DOWN-keys. Press the ENT-key.

Select the display 'CLEAR_MESSAGE_BUFFER' using the UP/DOWN-keys. Press the ENT-key.

The buffer is cleared. The display will return to the previous one used.

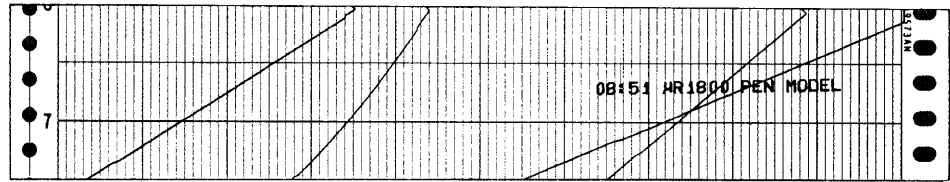

Figure 5.13a Message Printout Example in case of Pen Model

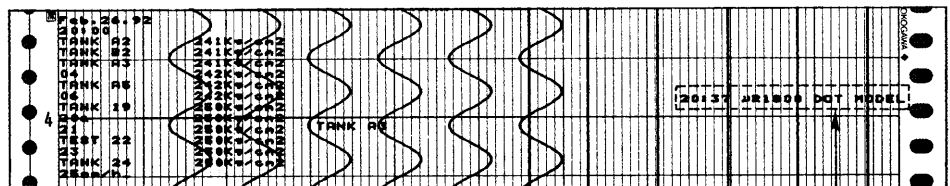

Figure 5.13b Message Printout Example in case of Dot Model

Message printout

NOTE The μ R1800 will store up to 5 messages in a buffer memory, regardless whether recording is ON or OFF. If more messages are generated, the new ones will not be kept in the buffer memory.

5.3.7 How to Acknowledge an Alarm

When an alarm occurs, the output relays (if installed) will be activated and the alarm indicator will behave as described below (see also figure 5.14):

Non-hold Type (for hold/non-hold selection, see 9.1.4 and 9.1.5):

when alarm occurs: the output relay will be activated
the indicator will lighten

when alarm recovers: the output relay will be reset
the indicator will stop lighting

Pressing the ACK-key has no effect.

Hold Type (for hold/non-hold selection, see 9.1.4 and 9.1.5):

when alarm occurs: the output relay will be activated
the indicator will start flashing; however, pressing the ACK-key results in showing the current alarm status (alarm in progress = ON, alarm recovered = OFF)

when alarm recovers: the output relay will be kept activated; however, pressing the ACK-key results in resetting the relay.
the indicator will keep flashing; however, pressing the ACK-key results in showing the current alarm status (alarm in progress = ON, alarm recovered = OFF)

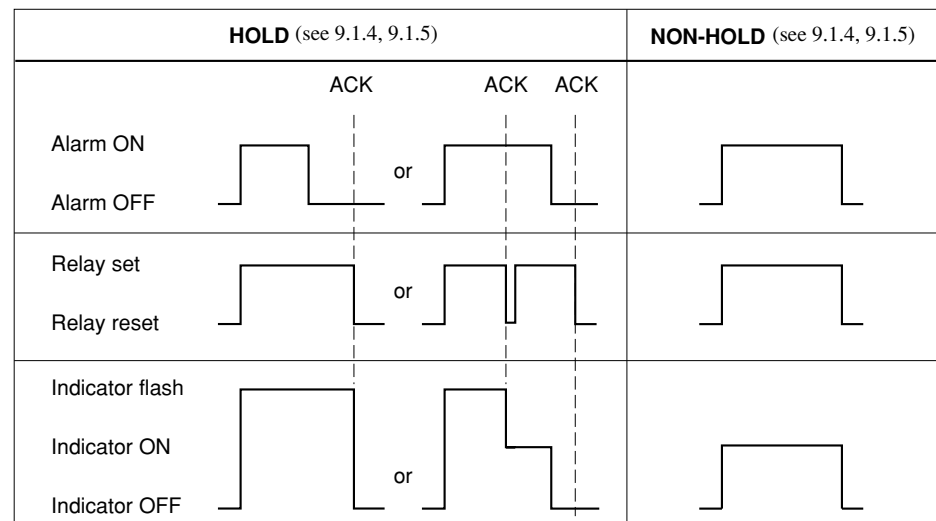

Figure 5.14

When an alarm occurs, you will see this on the display and alarm data will be printed on the chart. See 1.2 for an example.

When several alarms are generated in a short time, they will be stored in a buffer memory before printing on the chart. It is possible to clear this buffer, which can be useful for example in case the printing will take too much time. When the buffer is full, this will be indicated by an asterisk (*) in the latest alarm printout. As a result the next alarm is lost and will not be printed.

To clear the buffer memory, proceed as follows:

Press the MENU-key.

Select the display 'MENU=SELECT_FUNCTION' using the UP/DOWN-keys. Press the ENT-key. Select the display 'CLEAR_ALARM_BUFFER' using the UP/DOWN-keys. Press the ENT-key.

The buffer is cleared. The display will return to the previous one used.

NOTE The μ R1800 will store up to 8 (pen model) or 12 (dot model) alarms in a buffer memory. If more alarms are generated, the new ones will not be kept in the buffer memory.

5.3.8 How to Select the Display

Four different displays can be selected. These are:

DISPLAY AUTO:

Channel number or tag, measured values and units will appear on the display alternately. Every channel will be shown for approximately 2 sec. If the input is greater than the upper limit of the recording span, + ***** will appear.

If the input is less than the lower limit of the recording span, - ***** will appear.

Depending on whether you set tags (and specified this as explained in 9.4.1), the display will look like either one of the following:

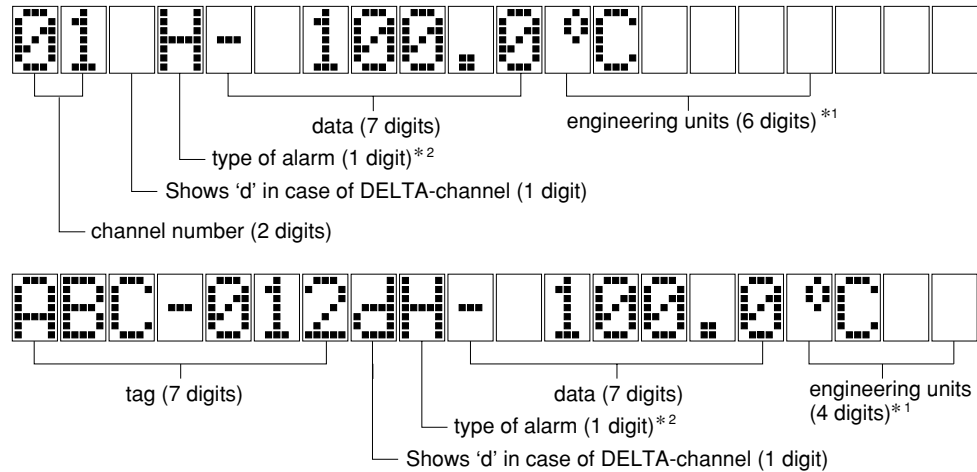

*1 Units are fixed for Voltage-input (mV/V) and for TC and RTD-input (°C/°F), and settable for SCL (scale input) and SQRT (square root input).

*2 Type of alarm: H: high limit R: rate-of-change on increasing signal
L: low limit r: rate-of-change on decreasing signal
h: high difference limit l: low difference limit

DISPLAY MAN:

Channel number or tag, measured values and units will appear on the display for a specific channel only. This display looks the same as the AUTO display (not available on 1 pen model).

DISPLAY CLOCK:

Date and time will appear on the display. Leap years are provided.

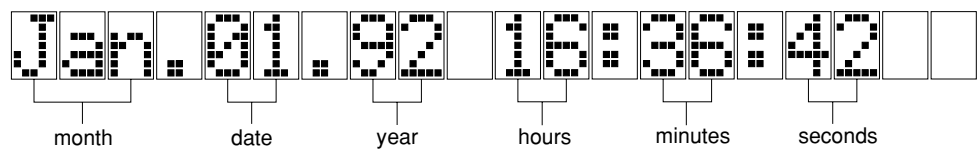

DISPLAY VIEW:

Status of the IC Memory Card (option) will appear on the display. If the option is not installed, the display will be black. For details concerning the VIEW display, see the option manual concerning the IC Memory Card (IM 4H3B1-30E) or the option manual concerning the mathematical functions (IM 4H3B1-20E).

How to select the desired display is described below.

Starting from the basic operation display, press the MENU-key. Select the display 'MENU=SELECT_DISPLAY' using the UP/DOWN-keys. Then press the ENT-key. You have now entered the following flow:

```
DISPLAY_AUTO
DISPLAY_MANUAL      MANUAL CH=?
DISPLAY_CLOCK
DISPLAY_VIEW
```

Moving between the different displays can be done by using the UP/DOWN-keys. Once you selected the desired display, press the ENT-key (In the case of the manual display, select the channel number by using the UP/DOWN-keys. Then press the ENT-key again).

After having pressed the ENT-key, the selected display will appear.

If you want to change the channel number while displaying the measured values on the manual display, you can change the channel number by pressing the ENT-key.

5.3.9 How to Cope with FAIL/Chart End

When equipped with this option and the chart reaches its end or a CPU-error occurs, the output relay will be activated. There is one output relay for Chart end detection, and one for FAIL detection. For the wiring, see 3.2.5.

CHART END:

When there are approx. 2cm left till chart end, the 'CHT' indicator will be illuminated in the display and recording will stop. To change the chart, follow the steps as explained in 5.2.1.

At the same time the output relay will be activated. This output relay is of the energizing type and this cannot be changed. See also the explanation mentioned below.

FAIL:

When a CPU-error occurs, the output relay will be activated. This relay is of the de-energizing type and this cannot be changed. Therefore this relay will also be activated when the power is off. The activating of this relay will not be shown on the display. See also the explanation mentioned below.

When a CPU-error occurs, contact the nearest Sales & Service Office. Addresses may be found on the back cover of this manual.

Explanation:

Chart end output relay (energize type):

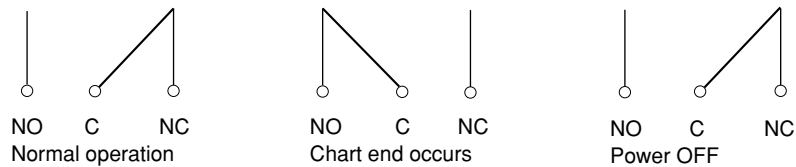

FAIL output relay (de-energize type):

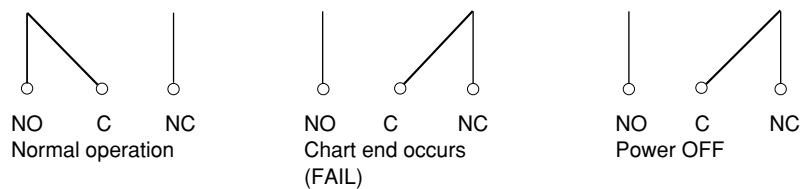

5.4 How to Use the Key-lock

In order to use this function, the settings for the key-lock must be set to 'USE'. See 9.10.

The key-lock is located in the keyboard at the top side. The keyboard is disabled when the plastic key is removed from the key-hole (see figure 5.15).

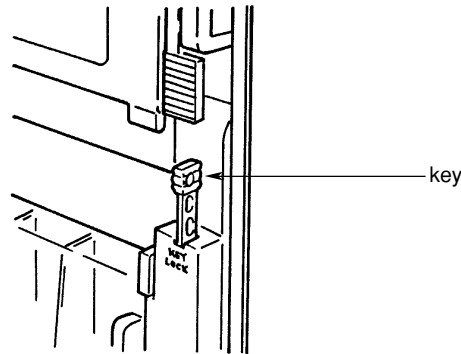

Figure 5.15 Key-lock

When you do not intend to operate the keyboard for a long time, you may lock the recorder to prevent operation by mistake. If the keys are disabled by the key-lock, you can still

- change the displays (as explained in 5.3.8)
- enter the SET UP Mode (as explained in 6.1)
- use the ESC function (as explained in 6.2).

You can set which keys will be affected by the key-lock. See 9.10.

- NOTE**
- If keys are disabled by the key-lock, you cannot enter the SET Mode (as explained in 6.1). Pressing the MENU-key for three seconds has no result.
 - Remote control signals and communication signals (optional) are not affected by the key-lock.

CAUTION

When locking, the key must be removed from the key-hole. Keep it in a safe place. Settings cannot be changed when the key is lost.

Chapter 6 HOW TO ENTER SETTINGS

This chapter describes the idea behind the settings of the μ R1800 Recorder. It is important to read this chapter carefully before entering or changing settings for the first time.

6.1 Explanation of Modes

To make the operation of the μ R1800 Recorder as easy as possible, the operation and setting are broken down into three modes. These are:

Operation Mode:

This mode is for basic operation, which is the operation on a daily basis, excluding settings. It includes operations like recording, chart feed, acknowledging alarms, printing out messages, lists and values.

When the power to the μ R1800 is turned ON, the recorder will be automatically in the operation mode. The operations within this mode are described in chapter 5.

SET Mode:

This mode will be used when setting parameters must be entered or changed. The parameters include not only settings of range and span, units, alarms, chart speed and clock, but also auxiliary settings which allow you to use the μ R1800's many functions. To enter the SET Mode, press the MENU-key for three seconds. To return to the operation mode, press the MENU-key for three seconds again.

The settings of range and span, units, alarms, chart speed and clock are all described in chapter 7.

The auxiliary settings (like for example zone recording settings) are all described in chapter 8.

SET UP Mode:

This mode will be used when initial settings must be changed. These settings are entered during the manufacturing of the recorder and seldom need to be changed. These settings include for example alarm relay adjustments, etc. To enter the SET UP Mode, press the ENT-key while turning ON the power.

Note that when you are in the SET UP Mode, the recording cannot be ON, and alarms will not be detected.

For a detailed overview of the initial settings, see 6.5.

For a description on how to perform the settings, see chapter 9.

The following figure shows the structure of modes.

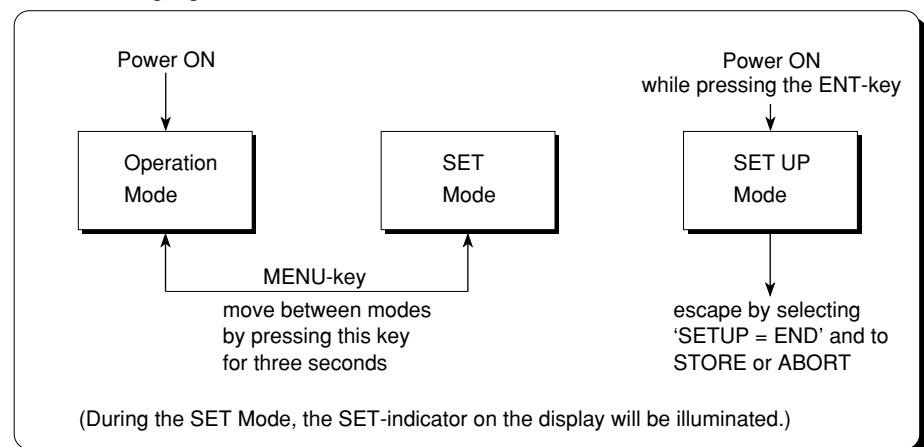

6.2 Concept of Setting Parameters

DISPLAY

The user interface is interactive, which means that you will be asked to enter the necessary data. All data can be entered using the keyboard. When entering data, the functions which are pictured above the actual keys are valid.

The display usually consists of two parts:



The parameters which need to be entered are shown in black with white letters in this manual. These parameters will flash on the actual display.

In this manual, you can also find another type of display:

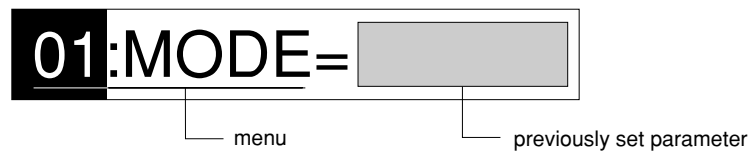

The blank means that the actual display will show your previously set data.

The display '*SET OK*' will appear once all the necessary parameters have been entered successfully. Pressing the ENT, UP, DOWN or RIGHT-key at those times will result in returning to the beginning of the same flow.

Pressing the ESC-key will result in returning to the previous level in the menu.

KEYS

Five keys on the keyboard can be used when entering data:

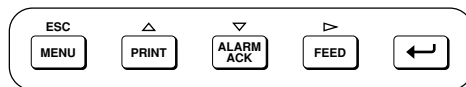

(The MENU-key is used to enter the SET Mode.)

The ESC-key can be used to abort the setting before the '*SET OK*' display appears. The display will return to the previous level in the menu. After the '*SET OK*' display appears, pressing the ESC-key will take you to the beginning of the same setting again.

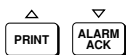

The UP/DOWN-keys can be used for moving through a menu. In the case of setting e.g. messages or units, these keys are used to select alphanumerical characters. UP shows the next choice, DOWN shows the previous choice.



The RIGHT-key can be used for moving the cursor to the next digit while entering parameters (e.g. in case of 0.000). Since there is no backspace key provided, this key will move to the first digit after the last digit.

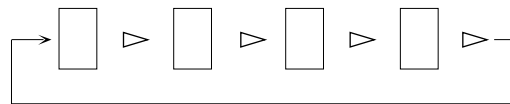

NOTE

In the case the decimal point is fixed, make sure to enter all digits.

Example: you entered result will be
 2. . . . 0.02 (entered value will be placed at last digit)
 2.00 2.00



The ENT-key is used for keeping the set parameters. After pressing this key, you will be asked to enter the next parameters.

In the case you entered incorrect data, but haven't pressed the ENT-key yet, use the UP/DOWN/RIGHT-keys to correct your error.

If you have pressed the ENT-key already, press the ESC-key and enter all necessary data again.

MENUS

In the paragraphs where the setting procedures are explained, you will find menus, like for example (as in chapters 7 and 8):

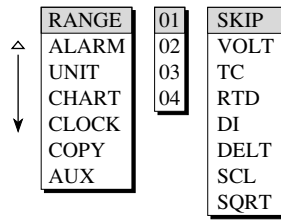

These menus will not be shown on the actual display. These are to make clear which steps need to be taken to set that parameter. Once you are familiar with the way to operate the μ R1800, these menus may be sufficient to you. Note that most of the menus used in this manual show the menu of the pen model.

6.3 Flow Charts

This paragraph describes the setting flows of the three modes. These are Operation Mode (6.3.1), SET Mode (6.3.2) and SET UP Mode (6.3.3).

6.3.1 Flow Chart of Operation Mode

This flow can be entered by pressing the corresponding function keys.

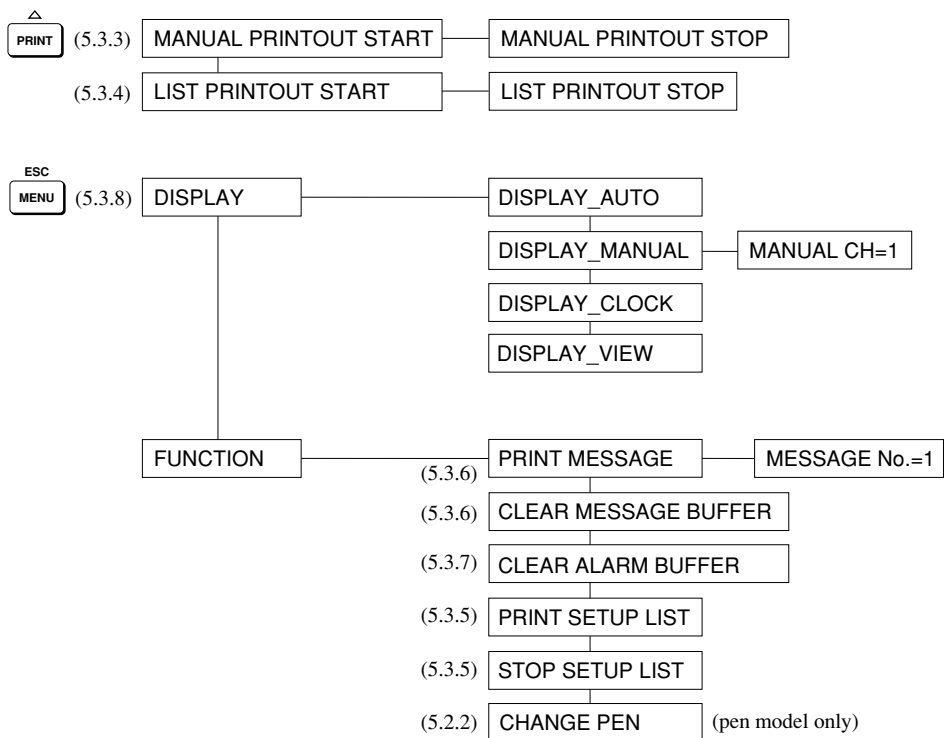

6.3.2 Flow Chart of SET Mode

This flow can be entered by pressing the MENU-key for three seconds.

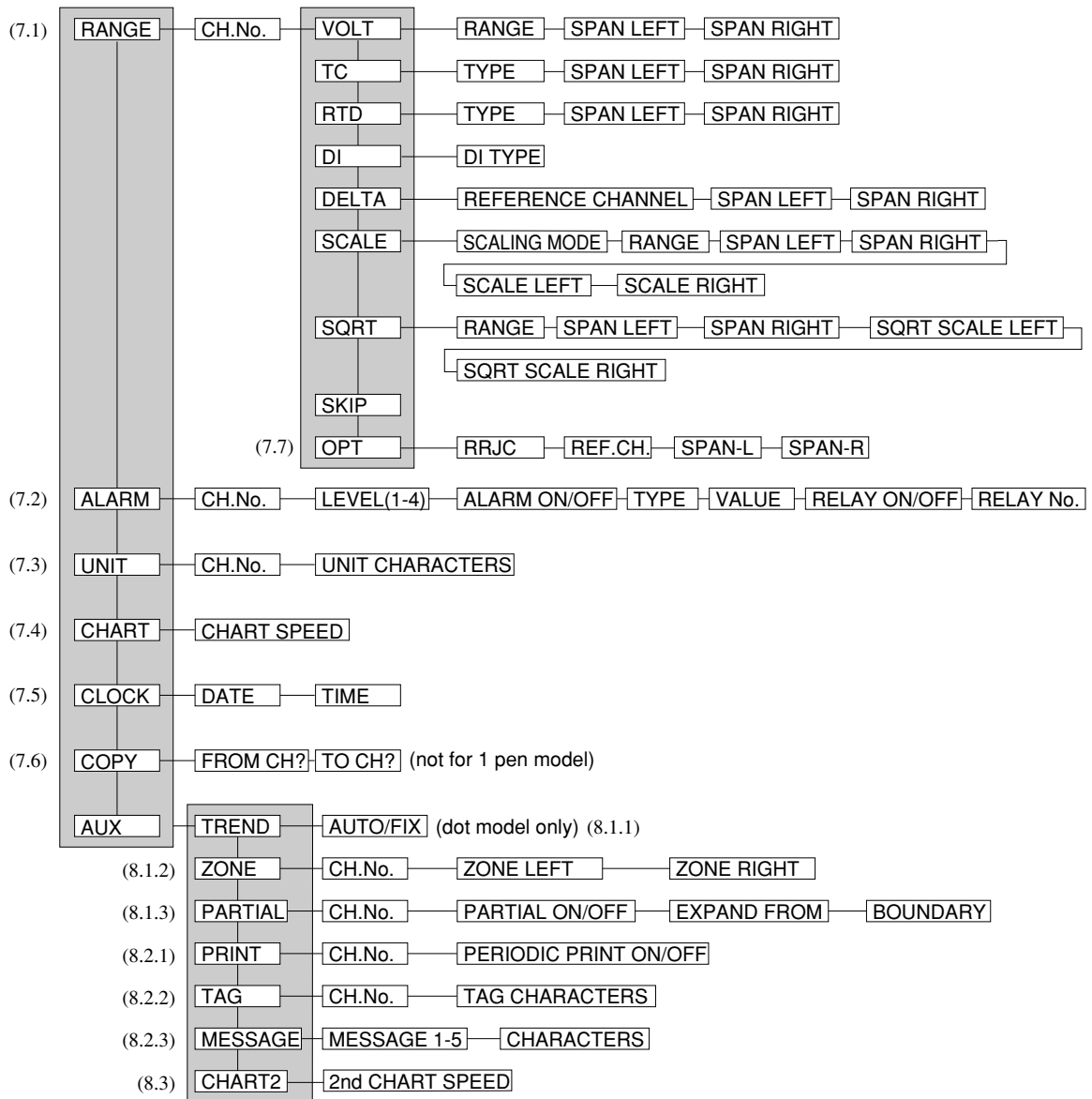

6.3.3 Flow Chart of SET UP Mode

This flow can be entered by turning ON the power while pressing the ENT-key.

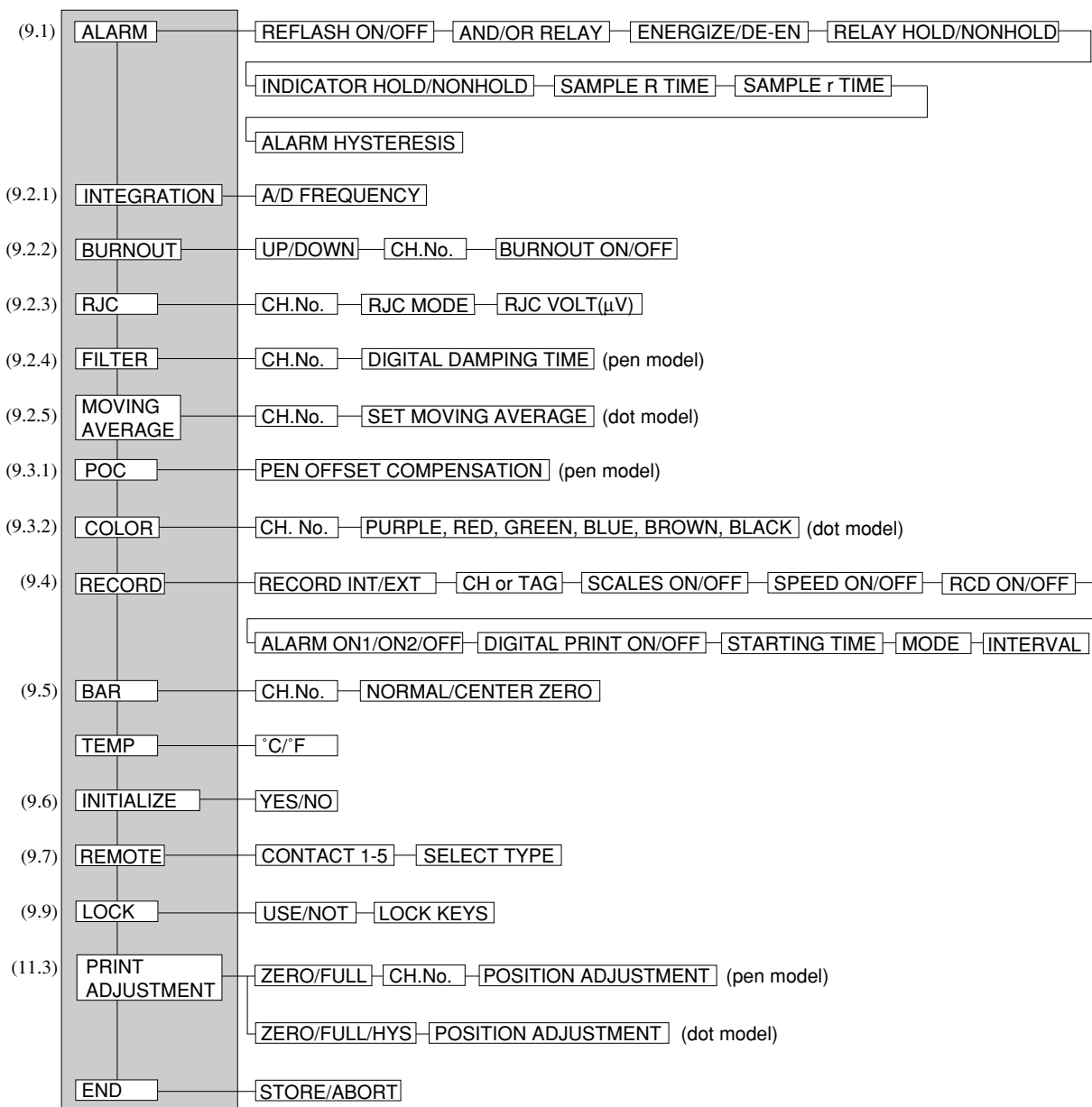

6.4 Setting Parameters in SET Mode

Setting Parameters			Values				Remarks
RANGE	MODE	VOLT	20mV	60mV	200mV	2V	DC voltage input
			6V	20V			
		TC	R	S	B	K	Thermocouple input
			E	J	T	N	
			W	L	U		
		RTD	JPT	PT			Input by Resistance Temperature Detector
		DI	LEVL	CONT			Digital Input LEVL: voltage input CONT: contact input
		DELT					Differential computation
		SCL	VOLT	TC	RTD		Assigning a different scale
		SQRT	20mV	60mV	200mV	2V	Taking square root of measured data
6V	20V						
SKIP					Skips a channel		
ALARM	LEVEL		1	2	3	4	
	Alarm		ON	OFF			Alarm setting ON/OFF
	TYPE		H	L	h	l	h and l can only be selected in combination with 'DELT' input.
			R	r			
	Alarm value						
	Relay		ON	OFF			
Relay No.		I01 to I24				Relay 1 to 24, depending on option	
UNIT							Assigning unit to scales. Only possible in case of SCL or SQRT. Max 6 characters.
CHART							Setting chart speed
CLOCK							Setting date and time
COPY							
AUX	TREND (dot model only)		AUTO	FIX			Selecting analog recording interval
	ZONE						Zone recording
	PARTIAL	partial	ON	OFF			Partial compression ON/OFF
		rate					Compression rate
		boundary					Boundary value
	PRINT	periodic printout	ON	OFF			Periodic printout ON/OFF
	TAG						Tag setting, max 7 characters
	MESSAGE		MSG1	MSG2	MSG3	MSG4	Max 5 messages, each up to 16 characters
			MSG5				
	Chart speed 2						Chart speed for change-on-alarm & remote

6.5 List of Initial Setting Values

SET Mode

RANGE	VOLT (-2.000V to 2.000V)
ALARM	OFF
UNIT	all spaces
CHART	25 mm/h
TREND	AUTO
ZONE	0 to 180mm
PARTIAL	OFF
PRINT	ON
TAG	all spaces
MESSAGE	all spaces
CHART2	25 mm/h

SET UP Mode

Function	Display	Initial Value
REFLASH function Output relay AND/OR Output relay ENERG/DE-EN Output relay HOLD/NONHOLD Alarm indicator HOLD/NONHOLD Sampling interval for rate-of-change alarm R Sampling interval for rate-of-change alarm r Alarm hysteresis	REFLASH= AND= ALARM= RLY= IND= R TIME= r TIME= ALM HYS=	OFF NONE ENERG NONHOLD NONHOLD 01 01 ON (approx. 0.5%)
A/D INTEGRATION TIME BURNOUT BURNOUT RJC Filter (pen model) Moving Average (dot model) Pen Offset Compensation (pen model) Color (dot model)	INTG= B.OUT= B.OUT= RJC= FILT= M AVE= POC= COLOR=	AUTO UP OFF for every channel INT for every channel OFF for every channel OFF for every channel OFF 1, 7, 13, 19=purple 2, 8, 14, 20=red 3, 9, 15, 21=green 4, 10, 16, 22=blue 5, 11, 17, 23=brown 6, 12, 18, 24=black
Record trigger CH/TAG Printout Scale Printout New chart speed Printout Record start time Printout Alarm Printout Periodic Printout Periodic Printout Mode Periodic Printout Interval	RECORD= CH/TAG= SCL PR= SPD PR= RCD PR= ALM PR= DGT PR= MODE= INTVL=	INT CH ON OFF OFF ON1 INT, START 00:00 AUTO 1h
Bargraph Remote control Key Lock	BAR= CONT.No.= LOCK=	NORML for every channel 1=RECORD 2=CHART SPEED 3=MANUAL PR 4=MESSAGE1 5=MESSAGE2 NOT

Chapter 7 BASIC SETTINGS

This chapter explains how to perform the settings of:
(Initial values are given in parentheses.)

- 7.1 Input range and recording span (VOLT, -2V to +2V)
- 7.2 Alarms (OFF)
- 7.3 Units (all spaces)
- 7.4 Chart speed (25 mm/h)
- 7.5 Clock

The last paragraph (7.6) explains how settings can be copied to other channels.

7.1 How to Set Input Range and Recording Span

One of the following parameters can be set for every channel:

- SKIP** Prevents the specified channel from being measured, recorded and displayed (7.1.1).
- VOLT** Measures and records DC-voltage (7.1.2).
- TC** Measures and records temperatures using Thermocouple (7.1.3).
- RTD** Measures and records temperatures using Resistance Temperature Detector (7.1.3).
- DI** Accepts Digital Input (contact/voltage level) and performs ON/OFF recording (7.1.4).
- DELT** Performs difference computation between two channels which have same input range (7.1.5).
- SCL** Performs scaling on voltage, TC and RTD measurements (7.1.6).
Scaling results in appending a different scale to the measured values.
- SQRT** Takes the square root ($\sqrt{\quad}$) of DC-voltage measured data (7.1.7).

7.1.1 SKIP Setting

Unused channels can be skipped, which means that these channels will not be measured, recorded or displayed.

MENU:

RANGE	01	SKIP
ALARM	02	VOLT
UNIT	03	TC
CHART	04	RTD
CLOCK		DI
COPY		DELT
AUX		SCL
		SQRT

SETTING PROCEDURE:

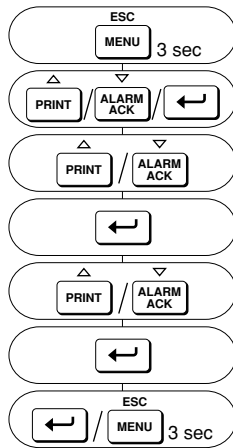

SET=RANGE Press the MENU-key for three seconds to enter the SET mode. Select the 'SET=RANGE' display by using the UP/DOWN-keys. Then press the ENT-key.

01:MODE= Use the UP/DOWN-keys to select the desired channel. Press the ENT-key.

01:MODE=SKIP Use the UP/DOWN-keys to select 'SKIP'. Press the ENT-key.

*** SET OK *** The setting is completed. Press the ENT-key to return to the '01:MODE=SKIP' display; or press the ESC-key to go to the 'SET=RANGE' display; or press the MENU-key for three seconds to return to the Operation mode.

7.1.2 Voltage Measurement Setting (VOLT Setting)

In the case that the measured signal is a DC-voltage, the range can be set as follows:

MENU:

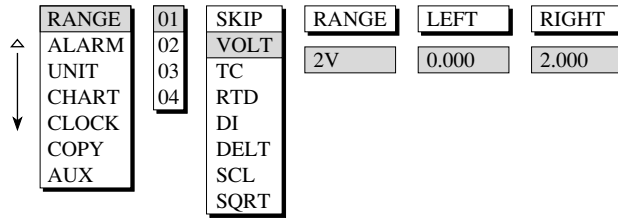

SETTING PROCEDURE:

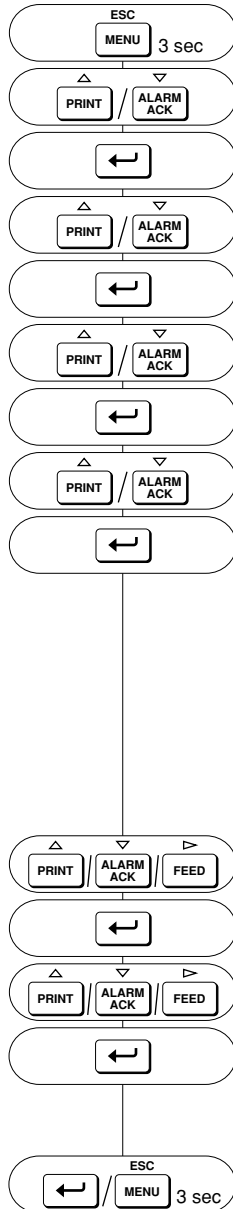

SET=RANGE Press the MENU-key for three seconds to enter the SET mode. Select the 'SET=RANGE' display by using the UP/DOWN-keys. Then press the ENT-key.

01:MODE= Use the UP/DOWN-keys to select the desired channel. Press the ENT-key.

01:MODE=VOLT Use the UP/DOWN-keys to select 'VOLT'. Press the ENT-key.

01:RANGE=2V Select the desired range using the UP/DOWN-keys and press the ENT-key.

Table 7.1 VOLT Input Ranges

Display	Range
20mV	-20.00 to 20.00mV
60mV	-60.00 to 60.00mV
200mV	-200.0 to 200.0mV
2V	-2.000 to 2.000V
6V	-6.000 to 6.000V
20V	-20.00 to 20.00V

01:LEFT=0.000 Select the minimum value of the recording span (LEFT) using the UP/DOWN and RIGHT-keys. Then press the ENT-key.

01:RIGHT=2.000 The display which appears will allow you to enter the maximum value of the recording span (RIGHT). Select it the same way as for the minimum value and press the ENT-key. Note that the recording span cannot be beyond the input range, nor can LEFT be equal to RIGHT.

*** SET OK *** The setting is completed. Press the ENT-key to return to the '01:MODE=VOLT' display; or press the ESC-key to go to the 'SET=RANGE' display; or press the MENU-key for three seconds to return to the Operation mode.

7.1.3 Thermocouple and Resistance Temperature Detector Setting (TC, RTD Setting)

In the case that the measured signal is a TC (Thermocouple) or RTD (Resistance Temperature Detector) the range can be set the same way as if it were a DC-voltage.

MENU:

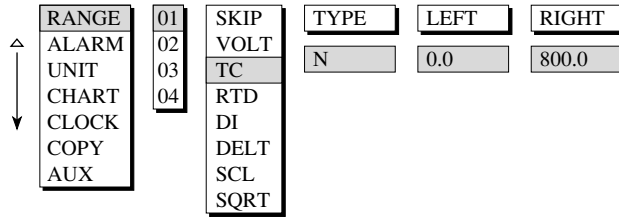

SETTING PROCEDURE:

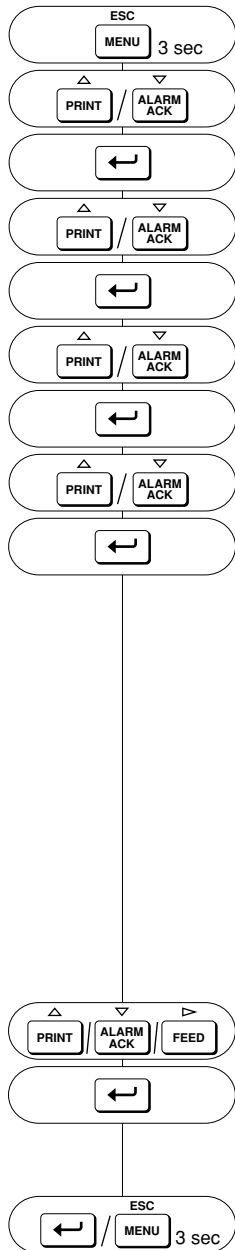

SET=RANGE Press the MENU-key for three seconds to enter the SET mode. Select the 'SET=RANGE' display by using the UP/DOWN-keys. Then press the ENT-key.

01:MODE= Use the UP/DOWN-keys to select the desired channel. Press the ENT-key.

01:MODE=TC Use the UP/DOWN-keys to select 'TC', or 'RTD'. Press the ENT-key.

01:TYPE=N Select the desired type (R, S, B, K, E, J, T, N, W, L, U in case of TC, or PT, JPT in case of RTD) using the UP/DOWN-keys and press the ENT-key.

Table 7.2 TC Type Description and RTD Type Description

TC Type Description			RTD Type Description		
	Range			Range	
R	0.0 to 1760.0°C	32 to 3200°F	PT (pt100Ω)	-200.0 to 600.0°C	-328.0 to 1112.0°F
S	0.0 to 1760.0°C	32 to 3200°F	JPT (Jpt100Ω)	-200.0 to 550.0°C	-328.0 to 1022.0°F
B	0.0 to 1820.0°C	32 to 3308°F	JP50 (JP50Ω)*1	-200.0 to 600.0°C	-328.0 to 1112.0°F
K	-200.0 to 1370.0°C	-328 to 2498.0°F	CU1 to 6 (Cu10Ω)*2	-200.0 to 300.0°C	-328.0 to 572.0°F
E	-200.0 to 800.0°C	-328.0 to 1472.0°F	CU25 (Cu25Ω)*2	-200.0 to 300.0°C	-328.0 to 572.0°F
J	-200.0 to 1100.0°C	-328.0 to 2012.0°F	*1: For /N3 model		
T	-200.0 to 400.0°C	-328.0 to 752.0°F	*2: For /N1 model		
N	0.0 to 1300.0°C	32 to 2372°F	The Pt and JPt type can't be set together with the Cu types.		
W	0.0 to 2315.0°C	32 to 4199°F	Cu1: Cu10Ω GE		
L (Fe-CuNi)	-200.0 to 900.0°C	-328.0 to 1652.0°F	Cu2: Cu10Ω L&N		
U (Cu-CuNi)	-200.0 to 400.0°C	-328.0 to 752.0°F	Cu3: Cu10Ω WEED		
PLT (PRATINEL)*1	0.0 to 1400.0°C	32 to 2552°F	Cu4: Cu10Ω BAILAY		
PR (PR40-20)*1	0.0 to 1900.0°C	32 to 3452°F	Cu5: Cu10Ω α=0.0392 at 20°C		
			Cu6: Cu10Ω α=0.0393 at 20°C		
			Cu25: Cu25Ω α=0.00425 at 0°C		

01:LEFT=0.0
01:RIGHT=800.0 Select the desired minimum value (LEFT) and maximum value of the recording span (RIGHT) in the same way as described under 'VOLT setting'.

Note that the recording span cannot be beyond the input range, nor can LEFT be equal to RIGHT.

*** SET OK *** The setting is completed. Press the ENT-key to return to the '01:MODE=TC' display; or press the ESC-key to go to the 'SET=RANGE' display; or press the MENU-key for three seconds to return to the Operation mode.

NOTE There is no need to set the temperature unit in case of TC or RTD input, since °C will be automatically provided. To change the setting of the temperature unit, which can only be changed in the SET UP Mode, see 9.6.

7.1.4 Digital Input Setting (DI Setting)

If a Digital Input (contact input/voltage level input) is being used, the setting can be done as follows:

MENU:

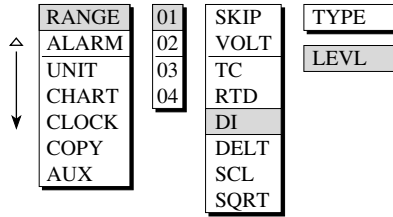

SETTING PROCEDURE:

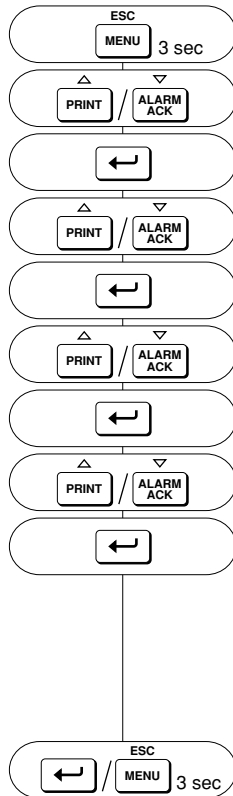

SET=RANGE Press the MENU-key for three seconds to enter the SET mode. Select the 'SET=RANGE' display by using the UP/DOWN-keys. Then press the ENT-key.

01:MODE= Use the UP/DOWN-keys to select the desired channel. Press the ENT-key.

01:MODE=DI Use the UP/DOWN-keys to select 'DI'. Press the ENT-key.

01:TYPE=LEVEL There are two types, namely LEVEL and CONTACT.
LEVEL: (VOLT) Records ON/OFF status of a voltage input (0 to 2.4V is OFF (0), 2.4V and higher is ON (1)).
CONT: (Contact) Records ON/OFF status of a contact (close is ON (1), open is OFF (0)).
 Select the desired type using the UP/DOWN-keys and press the ENT-key.

*** SET OK *** The setting is completed. Press the ENT-key to return to the '01:MODE=DI' display; or press the ESC-key to go to the 'SET=RANGE' display; or press the MENU-key for three seconds to return to the Operation mode.

NOTE The above mentioned selections will result in a recording trace from 0mm to 180mm between the contact statuses OFF and ON, which is from the extreme left side of the chart to the extreme right side. If desired, a zone for the ON/OFF recording can be set. See 8.1.2.

7.1.5 Difference Computation Setting (DELT Setting)

To obtain the difference between the measured values of two channels, proceed as follows. Note that this setting can only be applied if the reference channel is of the VOLT, TC or RTD type.

MENU:

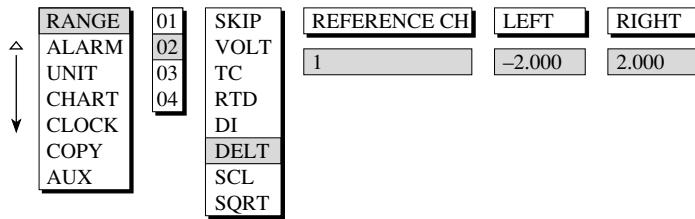

SETTING PROCEDURE:

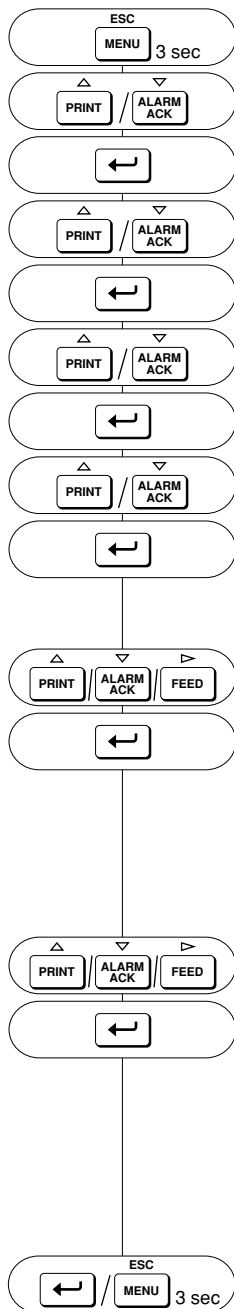

SET=RANGE Press the MENU-key for three seconds to enter the SET mode. Select the 'SET=RANGE' display by using the UP/DOWN-keys. Then press the ENT-key.

02:MODE= Use the UP/DOWN-keys to select the desired channel. Note that channel No.1 cannot be of the 'DELT' type. Then press the ENT-key.

02:MODE=DELT Use the UP/DOWN-keys to select 'DELT'. Then press the ENT-key.

02:REFERENCE CH=01 Enter the reference channel number using the UP/DOWN-keys. Note that the reference channel number must be lower than that of the channel being set. Therefore channel No.1 cannot be of the 'DELT' type. Then press the ENT-key.

02:LEFT=-2.000 The display which appears will show the same minimum value of the recording span as of the reference channel. Use the UP/DOWN and RIGHT-keys to set the minimum value. Press the ENT-key. Note that in case of VOLT, the input range of the DELT-channel must be within the range of the reference channel. The difference in measured value from the reference channel will be recorded on the DELT-channel.

02:RIGHT=2.000 The display which appears will show the same maximum value of the recording span as of the reference channel. Use the UP/DOWN and RIGHT-keys to set the maximum value. Note that LEFT cannot be equal to RIGHT. Press the ENT-key. Note that in case of TC, RTD, the maximum span values can be found by taking the \pm value of the input range width. E.g. input range of TC type L = -200 to 900°C : maximum span values will be at $\pm 1100^{\circ}\text{C}$.

*** SET OK *** The setting is completed. Press the ENT-key to return to the '02:MODE=DELT' display, or press the ESC-key to go to the 'SET=RANGE' display; or press the MENU-key for three seconds to return to the Operation mode.

7.1.6 Scale Setting (SCL Setting)

To assign a different scale to the measured data, the range can be set as described below. Note that the measured data which can get a different scale must be of the voltage (VOLT), Thermocouple (TC) or Resistance Temperature Detector (RTD) type. To assign a unit to this new scale, refer to UNIT setting (7.3).

MENU:



SETTING PROCEDURE:

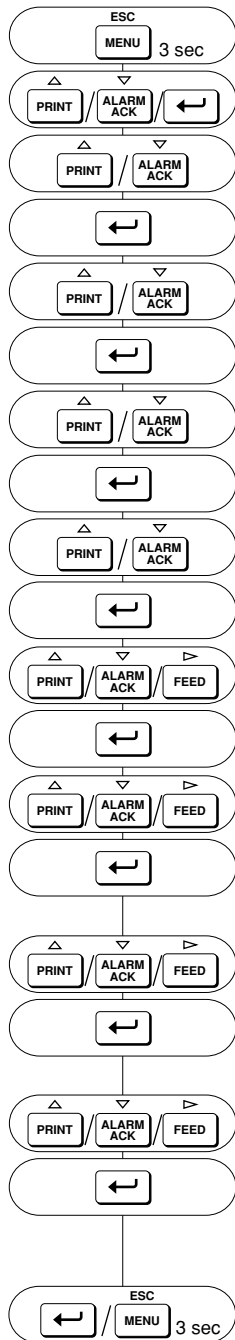

- SET=RANGE** Press the MENU-key for three seconds to enter the SET mode. Select the 'SET=RANGE' display by using the UP/DOWN-keys. Then press the ENT-key.
- 01:MODE=** Use the UP/DOWN-keys to select the desired channel. Press the ENT-key.
- 01:MODE=SCL** Use the UP/DOWN-keys to select 'SCL'. Press the ENT-key.
- 01:SCALING MODE=VOLT** Select the input type using the UP/DOWN-keys and press the ENT-key.
- 01:RANGE=2V** Select the desired range (using the UP/DOWN-keys) and press the ENT-key.
- 01:LEFT=0.000** Set the minimum value of the recording span using the UP/DOWN and RIGHT-keys. Then press the ENT-key.
- 01:RIGHT=2.000** Set the maximum value of the recording span using the UP/DOWN and RIGHT-keys. Then press the ENT-key. Note that the decimal point will be in the same position as for LEFT. LEFT cannot be equal to RIGHT.
- 01:SCL LEFT=-100.0** Set the minimum value of the scale corresponding to the minimum value of the recording span using the UP/DOWN and the RIGHT-keys. Note that the allowable range is -20000 to 20000. Then press the ENT-key.
- 01:SCL RIGHT=100.0** Set the maximum value of the scale corresponding to the maximum value of the recording span. Select it the same way as the minimum value. Then press the ENT-key. Note that the decimal point will be in the same position as for SCL LEFT. SCL LEFT cannot be equal to SCL RIGHT.
- * SET OK *** The setting is completed. Press the ENT-key to return to the '01:MODE=SCL' display; or press the ESC-key to go to the 'SET=RANGE' display; or press the MENU-key for three seconds to return to the Operation mode.

NOTE In this example, 0.000V input will be scaled to -100.0. 2.000V input will be scaled to 100.0.

7.1.7 Setting to Obtain Square Root (SQRT Setting)

To obtain the square root of the measured value, proceed as follows:

Note that the measured data of which the square root can be taken, can only be of the voltage type. To assign a unit, refer to UNIT setting (7.3).

MENU:

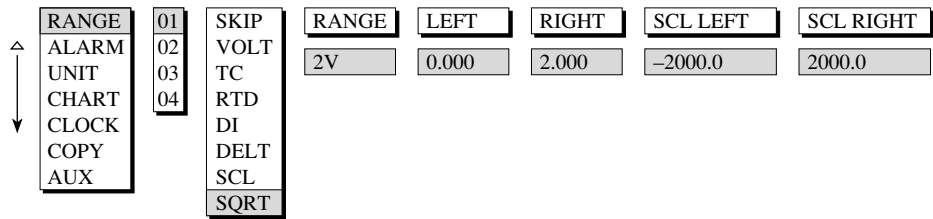

SETTING PROCEDURE:

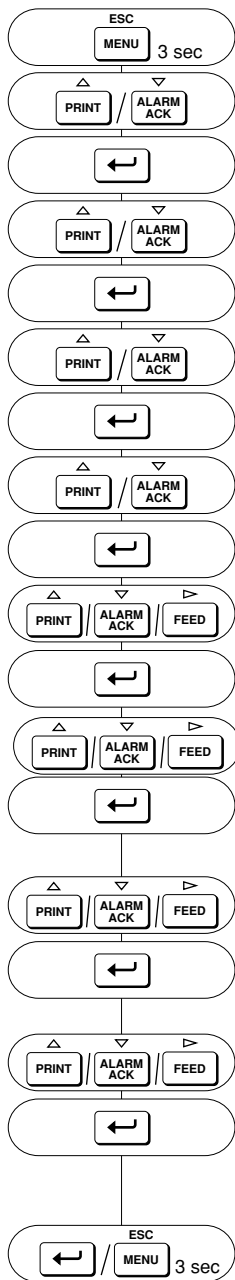

SET=RANGE Press the MENU-key for three seconds to enter the SET mode. Select the 'SET=RANGE' display by using the UP/DOWN-keys. Then press the ENT-key.

01:MODE= Use the UP/DOWN-keys to select the desired channel. Press the ENT-key.

01:MODE=SQRT Use the UP/DOWN-keys to select 'SQRT'. Press the ENT-key.

01:RANGE=2V Select the desired range (using the UP/DOWN-keys) and press the ENT-key.

01:LEFT=0.000 Set the minimum value of the recording span using the UP/DOWN and RIGHT-keys. Then press the ENT-key.

01:RIGHT=2.000 Set the maximum value of the recording span using the UP/DOWN and RIGHT-keys. Then press the ENT-key. Note that the decimal point will be in the same position as for LEFT. LEFT cannot be equal to RIGHT.

01:SCL LEFT=-2000.0 Set the minimum value of the scale corresponding to the minimum value of the recording span using the UP/DOWN and the RIGHT-keys. Note that the allowable range is -20000 to 20000. Then press the ENT-key.

01:SCL RIGHT=2000.0 Set the maximum value of the scale corresponding to the maximum value of the recording range. Select it the same way as the minimum value. Then press the ENT-key. Note that the decimal point will be in the same position as for SCL LEFT. SCL LEFT cannot be equal to SCL RIGHT.

*** SET OK *** The setting is completed. Press the ENT-key to return to the '01:MODE=SQRT' display; or press the ESC-key to go to the 'SET=RANGE' display; or press the MENU-key for three seconds to return to the Operation mode.

EXPLANATION OF SQUARE ROOT:

The $\mu R1800$ uses the following square rooting-method:

Let us define the items as follows:

V_{min} = minimum value of recording span (LEFT)

V_{max} = maximum value of recording span (RIGHT)

F_{min} = minimum value of scale (SCL LEFT)

F_{max} = maximum value of scale (SCL RIGHT)

V_x = input voltage

F_x = scaling value

The relationship between V_x (input voltage) and F_x (scaling value) is as shown in the graph below (the graph configuration is approximate).

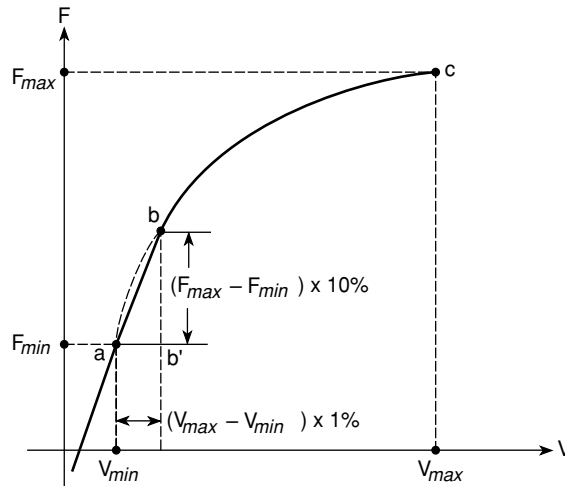

Between b and c in the graph, the following relation exists between F_x and V_x :

$$F_x = (F_{max} - F_{min}) \sqrt{\frac{V_x - V_{min}}{V_{max} - V_{min}}} + F_{min}$$

And between a and b, the relation is:

$$F_x = \frac{10 (F_{max} - F_{min})}{V_{max} - V_{min}} (V_x - V_{min}) + F_{min}$$

7.2 How to Set Alarms

Alarms can be set on the measured data of any channel.

If an alarm is set, and an alarm occurs, the ALM indicator will be illuminated and alarm printout will occur.

If equipped with the optional alarm output relays, these will be activated by the occurrence of an alarm.

Up to four alarm levels can be set per channel.

Six types of alarms are available. These are:

- H High limit alarm: alarm is generated when the measured value is higher than, or equal to, the alarm value.
- L Low limit alarm: alarm is generated when the measured value is lower than, or equal to, the alarm value.
- R Rate-of-change limit on increase: high alarm is generated when the measured value variation in the ascending direction during a selected interval is greater than, or equal to, the alarm setting.
- r Rate-of-change limit on decrease: low alarm is generated when the measured value variation in the descending direction during a selected interval is greater than, or equal to, the alarm setting.

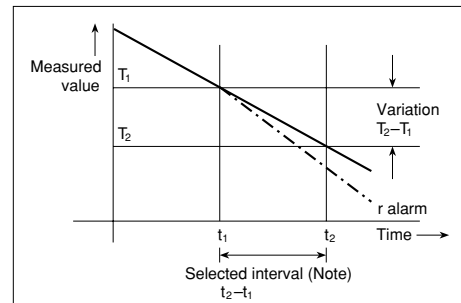
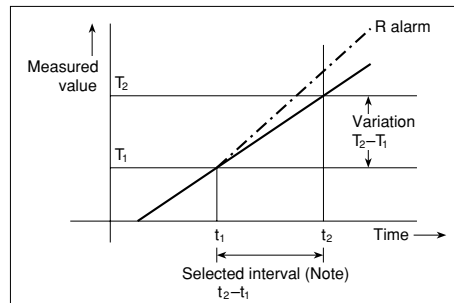

Note: the selected interval is determined during rate-of-change alarm set-up. See 9.1.6.

- h Difference high-limit alarm: alarm is generated when the difference between the measured values of two channels is more than the alarm setting. (This type of alarm can only be set when the corresponding channel is of the DELT-type.)
- l Difference low-limit alarm: alarm is generated when the difference between the measured values of two channels is less than the alarm setting. (This type of alarm can only be set when the corresponding channel is of the DELT-type.)

NOTE Alarm settings are automatically canceled on the affected channel, when any of the following changes occur:

- the input type (VOLT, TC, etc.) or input range (2V, etc.) is changed.
- decimal point for linear scaling and square root is changed.
- minimum or maximum value of the recording span is changed (in case of linear scaling and square root).
- minimum or maximum value of the scale is changed (in case of linear scaling and square root).

Difference alarm settings (h, l) are canceled when any of the following changes occur:

- the reference channel is changed.
- the input type or range of the reference channel is changed.

The initial value is 'OFF' for all channels and all levels.
To set an alarm, proceed as follows:

MENU:

RANGE	01	LEVEL	ALARM ON/OFF	TYPE	VALUE	RELAY ON/OFF	RELAY No.
ALARM	02	1	ON	H	2.000	ON	I01
UNIT	03						
CHART	04						
CLOCK							
COPY							
AUX							

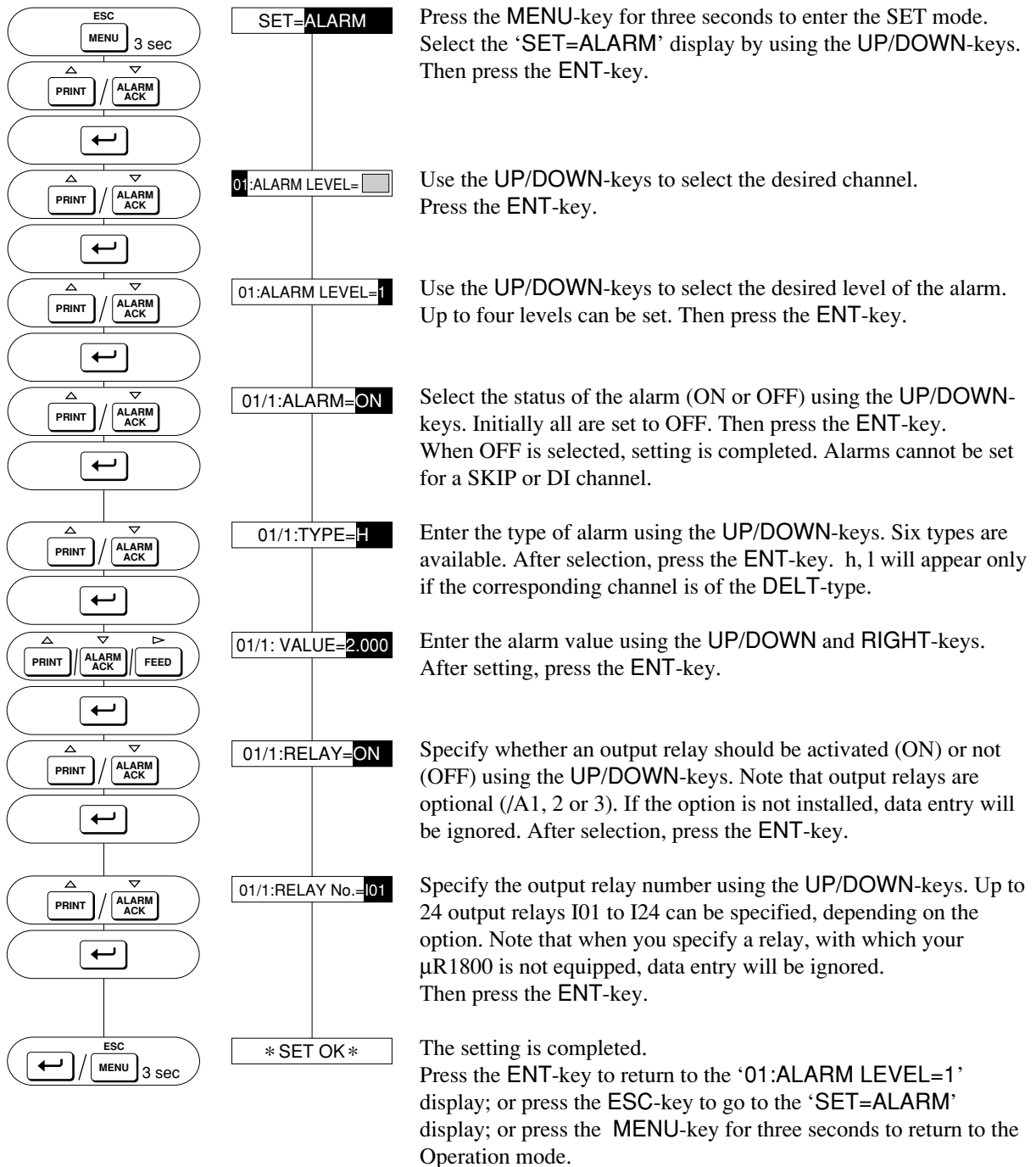
SETTING PROCEDURE:**NOTE**

Provided that your μ R1800 is equipped with the Remote Control /R1 option and the /A1, 2 or 3 option, the chart speed can be changed when an alarms occurs. See 8.3. The alarm relay can be of 2 types, the 'HOLD' type and 'NON-HOLD' type. See 9.1.4.

7.3 How to Assign Units

When you are using scaling (SCL) or the square root setting (SQRT), it is possible to assign a different unit to the scales. Up to six characters can be set. Note that only four characters will be shown on the display when tags are specified. The initial value is all spaces. To set, proceed as follows:

MENU:

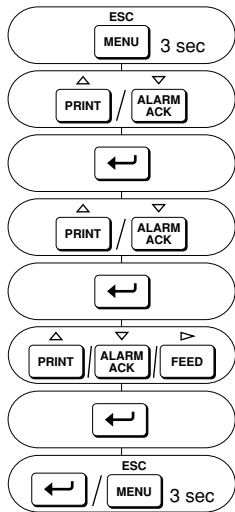
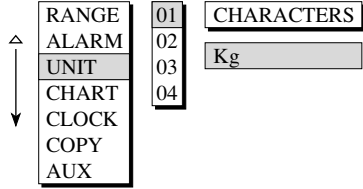

SETTING PROCEDURE:

SET=UNIT

Press the MENU-key for three seconds to enter the SET mode. Select the 'SET=UNIT' display by using the UP/DOWN-keys. Then press the ENT-key.

01:UNIT=

Use the UP/DOWN-keys to select the desired channel, and press the ENT-key. If the selected channel is not of the SCL or SQRT-type, data entry will be ignored.

01:UNIT=Kg

Enter the desired unit (up to six characters) using the UP/DOWN and RIGHT-keys. Then press the ENT-key. Refer to table 7.3.

* SET OK *

The setting is completed. Press the ENT-key to return to the '01:UNIT=Kg' display; or press the ESC-key to go to the 'SET=UNIT' display; or press the MENU-key for three seconds to return to the Operation mode.

Table 7.3 Characters

→ △-key	A	B	C	D	E	F	G	H	I	J
	K	L	M	N	O	P	Q	R	S	T
← ▽-key	U	V	W	X	Y	Z	a	b	c	d
	e	f	g	h	i	j	k	l	m	n
	o	p	q	r	s	t	u	v	w	x
	y	z	0	1	2	3	4	5	6	7
	8	9	#	%	()	+	-	*	/
	.	°	μ	Ω	∅					

7.4 How to Set the Chart Speed

The chart speed can be set within a range of 1 to 12000 mm/h, depending on your model. The initial value is 25 mm/h. To set the chart speed, proceed as follows:

MENU:

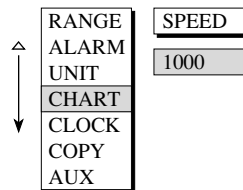

SETTING PROCEDURE:

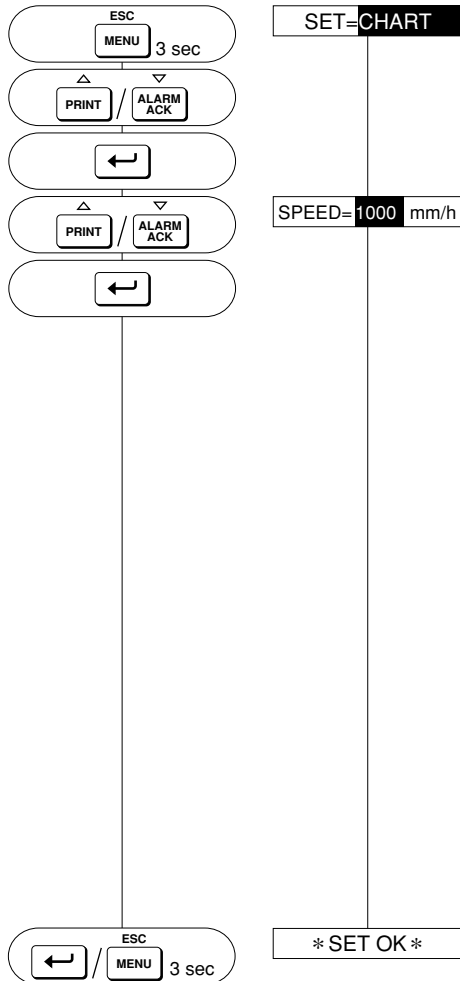

Press the MENU-key for three seconds to enter the SET mode. Select the 'SET=CHART' display by using the UP/DOWN-keys. Then press the ENT-key.

In case of the pen model, select the desired chart speed using the UP/DOWN-keys, and press the ENT-key. The different possible chart speeds are listed below in table 7.4.

In case of the dot model, set the desired chart speed using the UP/DOWN and RIGHT-keys, and press the ENT-key.

Check in table 7.5 that all the printouts will be printed as expected.

Table 7.4 Chart Speeds in mm/h (pen model)

5	6	8	9	10	12	15	16	18	20
24	25	30	32	36	40	45	48	50	54
60	64	72	75	80	90	96	100	120	125
135	150	160	180	200	225	240	250	270	300
320	360	375	400	450	480	500	540	600	675
720	750	800	900	960	1000	1080	1200	1350	1440
1500	1600	1800	2000	2160	2250	2400	2700	2880	3000
3600	4000	4320	4500	4800	5400	6000	7200	8000	9000
10800	12000								

Table 7.5 Chart Speeds for which Printouts will not be performed

Model	Periodic Printout	Alarm Printout/Recording Start/Message Printout/Chart Speed Change/Channel/Tag (dot model only)
pen	5 to 9 mm/h	1600 to 12000 mm/h
6/12 dot model	1 to 9 mm/h, 101 to 1500 mm/h	100 to 1500 mm/h
18/24 dot model	1 to 9 mm/h, 51 to 1500 mm/h	51 to 1500 mm/h

The setting is completed.

Press the ENT-key to return to the 'SPEED=1000 mm/h' display; or press the ESC-key to go to the 'SET=CHART' display; or press the MENU-key for three seconds to return to the Operation mode.

NOTE Setting the chart speed which goes into effect following a remote control signal (/R1 option), or following an alarm occurrence (/A1, 2 or 3 option + /R1 option), is performed under the AUX-settings. See 8.3.

If the chart speed is high (600 to 1500 mm/h) in case of the pen model, the time tick in the periodic printout will contain an error (e.g. if speed is 1500 mm/h, error will be approx. 2cm).

If you selected a chart speed of 1 to 5 mm/h, in case of the dot model, select AUTO for the trend recording format to prevent chart paper damage (see 8.1.1).

7.5 How to Set the Clock

To set the date and the time of the internal clock, proceed as follows:

MENU:

	DATE	TIME
	92/06/30	13:30:00
↑		
↓		

SETTING PROCEDURE:

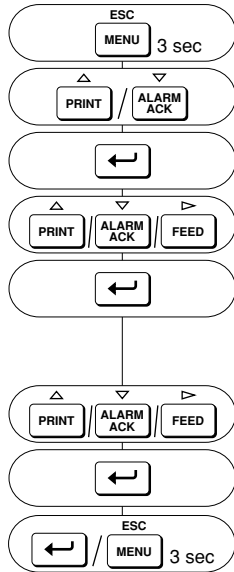

SET=CLOCK

Press the MENU-key for three seconds to enter the SET mode. Select the 'SET=CLOCK' display by using the UP/DOWN-keys. Then press the ENT-key.

DATE=92/06/30

Enter the correct date, which is written as year/month/day (YY/MM/DD) using the UP/DOWN/RIGHT-keys. Then press the ENT-key. The date will be automatically updated, regardless whether the power is turned ON or OFF. Leap years are automatically provided.

TIME=13:30:00

Enter the correct time, which is written as hour:minute:second (HH:MM:SS) using the UP/DOWN/RIGHT-keys and press the ENT-key. When pressing the ENT-key, the clock will start.

* SET OK *

The setting is completed. Press the ENT-key to return to the 'DATE=92/06/30' display; or press the ESC-key to go to the 'SET=CLOCK' display; or press the MENU-key for three seconds to return to the Operation mode.

7.6 How to Copy Channel Settings to Another Channel

It is possible to copy settings from one channel to another. If executed, all settings concerning range, alarm, unit, zone recording, partial expanded recording, periodic printout and tag will be copied. For the settings concerning zone recording, partial expanded recording, periodic printout and tag, see 8.1, 8.2. These settings will then all be copied; it is therefore impossible to copy e.g. alarm-settings only. The exact contents of these settings will be copied to the specified channel. Data entry will be ignored for the 1 pen model. To copy, proceed as follows:

MENU:

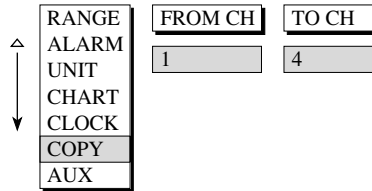

SETTING PROCEDURE:

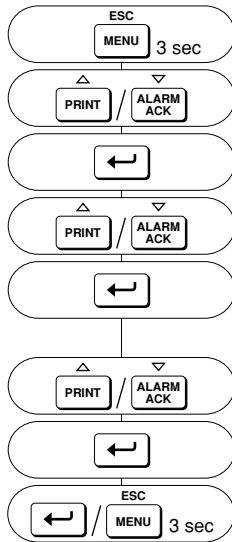

SET=COPY

Press the MENU-key for three seconds to enter the SET mode. Select the 'SET=COPY' display by using the UP/DOWN-keys. Then press the ENT-key.

COPY FROM 01 TO

Enter the channel number from which you want to copy using the UP/DOWN-keys. Note that you can only copy from a lower channel number to a higher channel number. Then press the ENT-key.

COPY FROM 01 TO 04

Then enter the channel number to which you want to copy using the UP/DOWN- keys. Then press the ENT-key.

* SET OK *

The setting is completed. Press the ENT-key to return to the 'COPY FROM _ TO _ ' display; or press the ESC-key to go to the 'SET=COPY' display; or press the MENU-key for three seconds to return to the Operation mode.

7.7 How to Set the Remote RJC (For /N5 Model)

When measuring a temperature by thermocouple (TC) and the object of measurement is located at a big distance, it is possible to measure the temperature without using a lot of expensive TC wires by establishing a relay terminal near the measurement object. The relay terminal and object of measurement are connected by TC. The relay terminal and input terminal of the main unit are connected by a compensating copper wire. One other input terminal of the main unit is connected with the relay terminal by TC and by conducting standard setting compensation of the to be measured temperature, which is done by measuring the temperature of the relay terminal, the temperature of the measurement object can be calculated. (Refer to the figure below.)

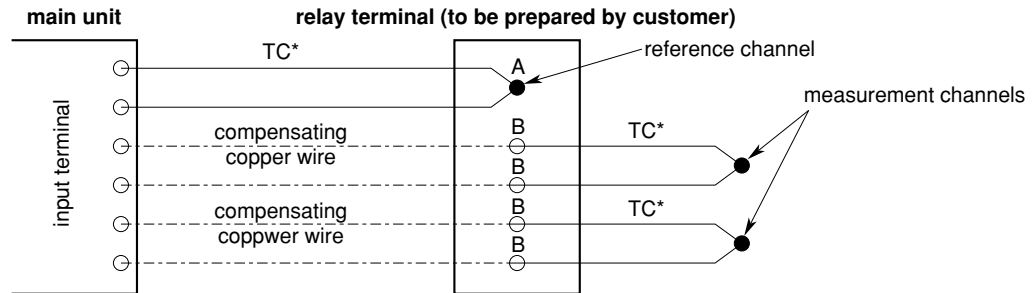

* Please use the same type of TC

- NOTES**
- The input mode of the reference channel should be same as the used TC.
 - The range of each measuring channel will become same as the range of the reference channel.
 - The limits of the span of the measuring channel are the same as for the usual TC input (refer to page 7-4).
 - Scaling is not possible.
 - In case you change the range or input mode of the reference channel, the input mode of the measurement channel being TC will not change, while the span becomes the upper/lower value of the newly set range.

MENU



RANGE	1
ALARM	2
UNIT	3
CHART	4
CLOCK	
COPY	
AUX	

SKIP	
VOLT	
TC	
RTD	
DI	
DELT	
SCL	
SQRT	
OPT	

RRJC
MATH

1
2
3
4

SPAN-L	SPAN-R
0.0	800.0

SETTING PROCEDURE:

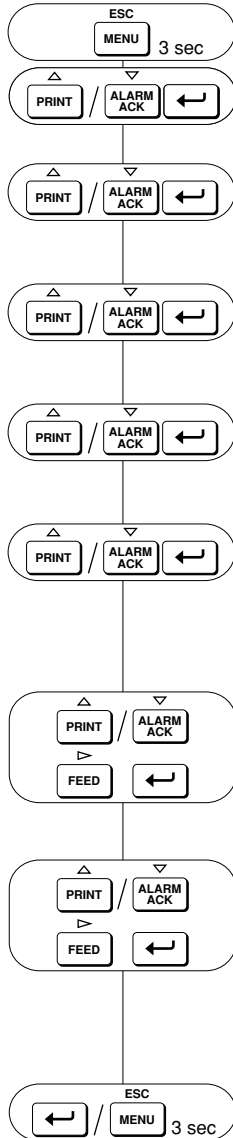

SET=RANGE

Press the MENU-key for three seconds to enter the SET mode. Select the 'SET=RANGE' display by using the UP/DOWN-keys. Then press the ENT-key.

2:MODE=TC

Use the UP/DOWN-keys to select the desired measuring channel. Press the ENT-key.

2:MODE=OPT

Use the UP/DOWN-keys to select 'OPT'. Press the ENT-key.

2:OPTION MODE=RRJC

Use the UP/DOWN-keys to select 'RRJC'. Press the ENT-key.

2:RJC CH=1

Use the UP/DOWN-keys to select the reference channel. Press the ENT-key. Note that the number of the reference channel must be lower than that of the measuring channel. If not, an error will occur.

2:LEFT= 0.0

Select the minimum value of the recording span (SPAN L) using the UP/DOWN and RIGHT-keys. Then press the ENT-key.

2:RIGHT= 800.0

The display which appears will allow you to enter the maximum value of the recording span (SPAN R). Select it the same way as for the minimum value and press the ENT-key. Note that the recording span cannot be beyond the input range, nor can SPAN L be equal SPAN R.

* SET OK *

The setting completed. Press the ENT-key to return to the '2:MODE=TC' display for other channel using the remote RJC; or press the ESC-key to go to the 'SET=RANGE' display; or press the MENU-key for three seconds to return to the Operation mode.

Chapter 8 AUXILIARY SETTINGS (AUX)

This chapter describes auxiliary settings, which are normally kept at their initial values but, in order to use the many functions of the μ R1800, might be changed. They are grouped into

- 8.1 Settings for analog recording
- 8.2 Settings for digital printing
- 8.3 How to set the chart speed used when change-on-alarm or remote control is selected.

8.1 Settings for Analog Recording

This paragraph describes:

- 8.1.1 How to adjust the trend recording format
- 8.1.2 How to set zone recording
- 8.1.3 How to set partial expanded recording.

Trend recording can be done depending on a fixed interval or an interval which depends on the chart speed.

Zone recording enables you to define different bands (zones) for each channel, so the recording traces will not overlap.

Partial expanded recording enables you to compress a part of the recording range, in order to examine the other part of the range in more detail.

Initial values are:

TREND AUTO
ZONE 0 to 180mm
PART OFF

8.1.1 How to Adjust the Trend Recording Format

The μ R1800 prints in FIX or AUTO mode.

In FIX mode, dot printing is performed with a constant interval regardless of the chart speed (approx. 10s for 6 dot, 15s for 12 dot, 20s for 18 dot and 30s for 24 dot model). AUTO mode is provided to prevent the chart from being damaged during repetitive dot printing. This mode is useful for low chart speeds. The chart is protected from damage because the printout timing changes with the chart speed (approx. 10 to 90 sec).

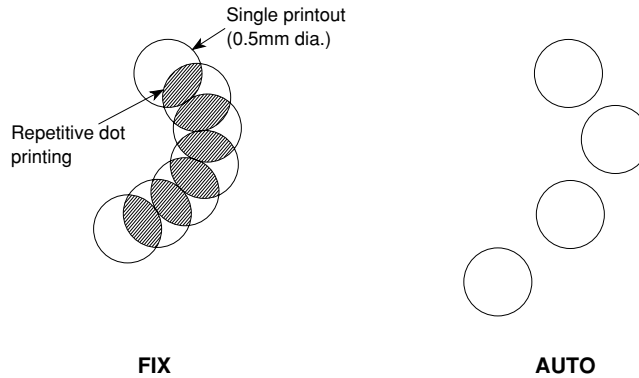

The initial value is 'AUTO'. To set the trend recording mode, proceed as follows:

MENU:

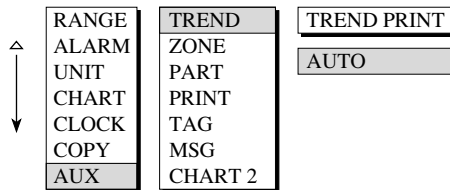

SETTING PROCEDURE:

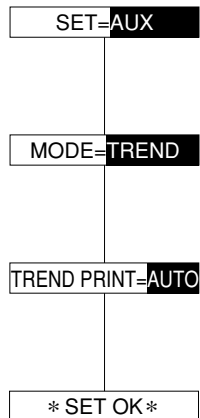
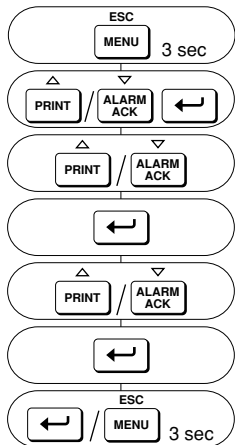

Press the MENU-key for three seconds to enter the SET mode. Select the 'SET=AUX' display using the UP/DOWN-keys, and press the ENT-key.

Select the 'MODE=TREND' display using the UP/DOWN-keys. Then press the ENT-key.

Specify AUTO or FIX using the UP/DOWN-keys. Then press the ENT-key.

The setting is completed. Press the ENT-key to return to the 'TREND PRINT=...' display, or press the ESC-key to go to the 'SET=AUX' display; or press the MENU-key for three seconds to return to the Operation mode.

8.1.2 How to Set Zone Recording

Zone recording enables you to define different bands (zones) for each channel, so the recording traces will not overlap during analog recording. The initial value is '0 to 180mm'.

To set the zones, proceed as follows:

MENU:

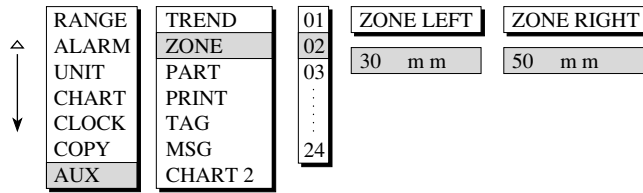

SETTING PROCEDURE:

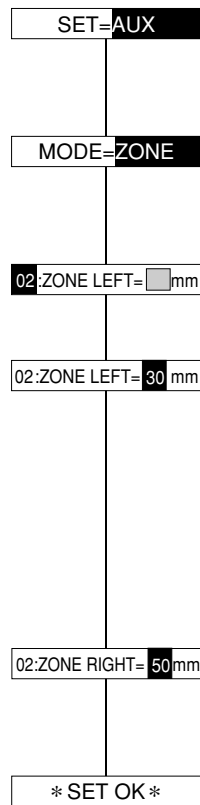
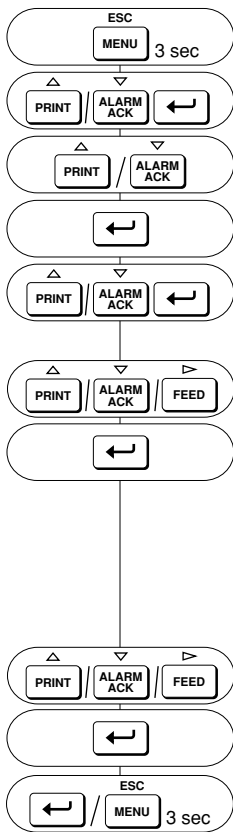

Press the MENU-key for three seconds to enter the SET mode. Select the 'SET=AUX' display using the UP/DOWN-keys, and press the ENT-key.

Select the 'MODE=ZONE' display using the UP/DOWN-keys. Then press the ENT-key.

Select the desired channel using the UP/DOWN-keys, and press the ENT-key.

Then specify the left boundary value using the UP/DOWN and the RIGHT-keys. On the chart paper this left boundary value will correspond with the left span value. (For example, if your channel 2 has a recording span of -2V to 2V, and you specify the zone to start from 30mm, then the recording at 30mm will correspond with the value of -2V.) Then press the ENT-key. Note that the minimum width of a zone is 5mm. The left boundary must be less than the right boundary.

Then specify the right boundary value using the UP/DOWN and the RIGHT-keys, and press the ENT-key. Note that scales will only be printed for 40mm and bigger zones.

The setting is completed. Press the ENT-key to return to the '02:ZONE LEFT=...mm' display, or press the ESC-key to go to the 'SET=AUX' display; or press the MENU-key for three seconds to return to the Operation mode.

EXPLANATION:

The next figure shows the recording after zone recording has been set (example).

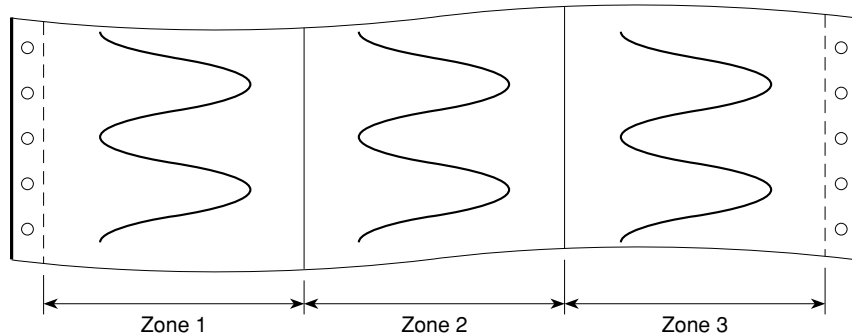
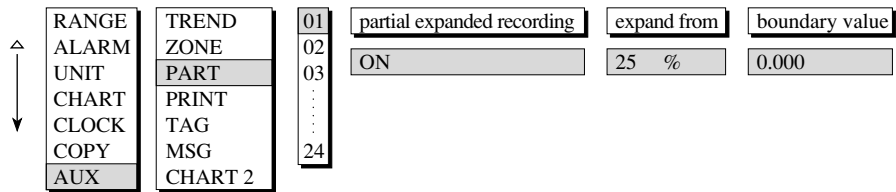

Figure 8.1 Zone Recording Example

8.1.3 How to set Partial Expanded Recording

Partial expanded recording enables you to compress a part of the recording span, in order to examine the expanded (other) part of the range in more detail. The initial value is 'OFF'. To set partial expanded recording, proceed as follows:

MENU:



SETTING PROCEDURE:

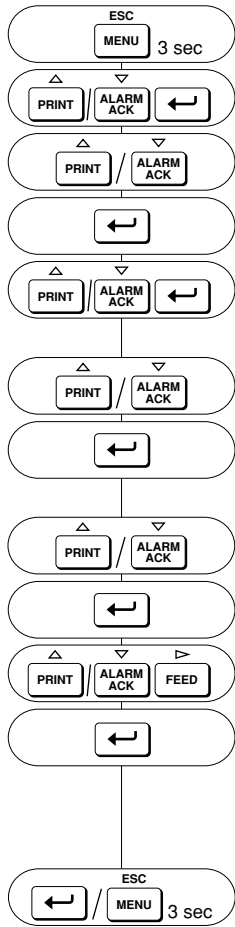

SET=AUX

Press the MENU-key for three seconds to enter the SET mode. Select the 'SET=AUX' display using the UP/DOWN-keys, and press the ENT-key.

MODE=PART

Select the 'MODE=PART' display using the UP/DOWN-keys. Then press the ENT-key.

01:PARTIAL=

Select the desired channel using the UP/DOWN-keys, and press the ENT-key.

01:PARTIAL=ON

Select ON (or OFF in case you had set partial expanded recording before and want to stop it now) using the UP/DOWN-keys. Then press the ENT-key. In the case you selected OFF, the setting is completed.

01:EXPAND FROM=25%

Specify the percentage (1 to 99%) of the full recording span which has to be compressed, using the UP/DOWN-keys. Press the ENT-key.

01:BOUNDARY=0.000

The display which appears prompts you to set the boundary value. The boundary value corresponds to the previous set compressed part. See also figure 8.3. Set this value by using the UP/DOWN and the RIGHT-keys. Note that this boundary value must be within the recording span. (If scaling is ON, this value must be within the scaling range.) Then press the ENT-key.

* SET OK *

The setting is completed. Press the ENT-key to return to the '01:PARTIAL=...' display, or press the ESC-key to go to the 'SET=AUX' display; or press the MENU-key for three seconds to return to the Operation mode.

NOTE

Partial Expanded settings are automatically canceled, when any of the following changes occur:

- the input type (VOLT, TC, etc.) or input range (2V, etc.) is changed.
- decimal point for linear scaling and square root is changed.
- minimum or maximum value of the recording span is changed (in case of linear scaling and square root).
- minimum or maximum value of the scale is changed (in case of linear scaling and square root).
- the reference channel is changed.
- the input type or range of the reference channel is changed.

EXPLANATION:

The next figures show the recordings before and after the above settings have been completed:

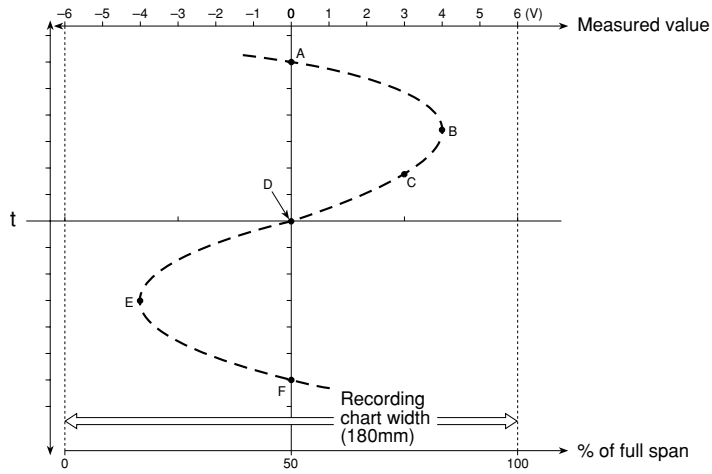

Figure 8.2 Normal Recording Example

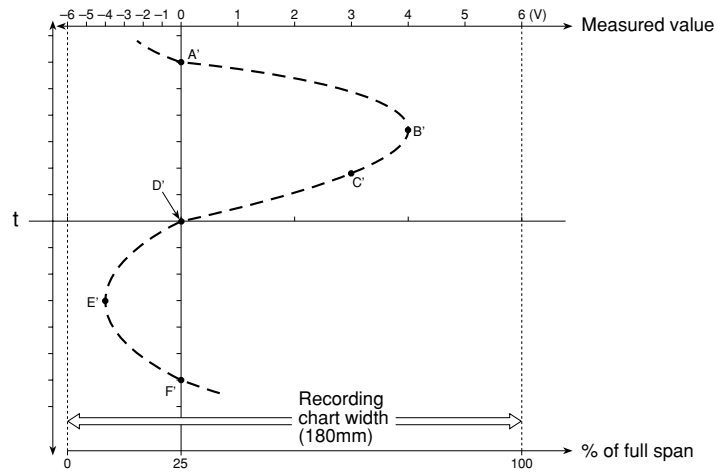

Figure 8.3 Partial Recording Example

As can be seen from these figures, the left side of the boundary (D') shows on 25% of the chart the data in the range -6V to 0V. On the right side of the boundary you can see the range 0V to 6V on 75% of the chart. Thus the scales differ on the left and right sides of the boundary.

8.2 Settings for Digital Printing

This paragraph describes how to select the periodic printout ON/OFF, how to set a tag and how to set a message.

Initial values are:

PRINT ON
 TAG all spaces
 MSG all spaces

8.2.1 How to Select the Periodic Printout ON/OFF

The printing of channel No., tag and the measured values in the periodic printout can be selected ON/OFF per channel. However, the periodic printout of date, time, chart speed and, for the pen model, pen color and POC ON mark (✕) cannot be OFF. The initial value is 'ON'.

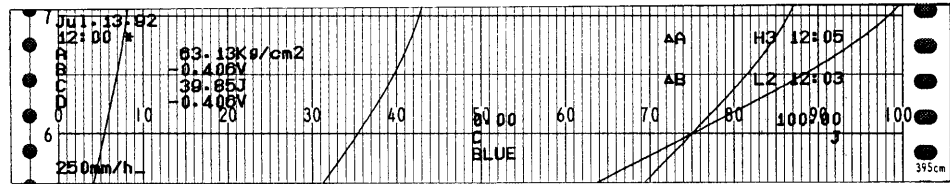

Figure 8.4a Periodic Printout for the Pen Model

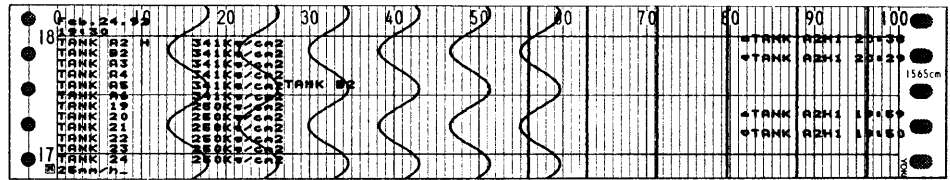
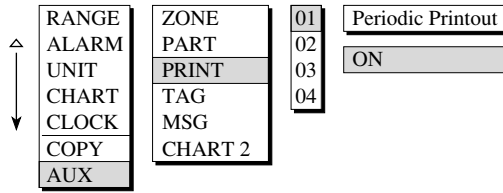

Figure 8.4b Periodic Printout for the Dot Model

To select this periodic printout ON or OFF, proceed as follows:

MENU:



SETTING PROCEDURE:

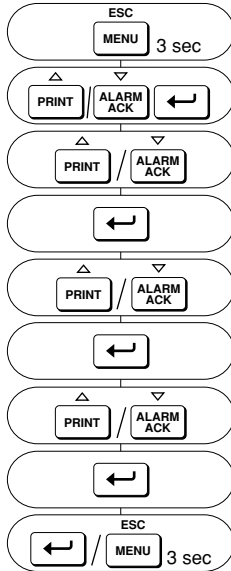

- SET=AUX** Press the MENU-key for three seconds to enter the SET mode. Select the 'SET=AUX' display using the UP/DOWN-keys, and press the ENT-key.
- MODE=PRINT** Select the 'MODE=PRINT' display using the UP/DOWN-keys. Then press the ENT-key.
- 01: DIGITAL PRINT=** Select the desired channel using the UP/DOWN-keys, and press the ENT-key.
- 01: DIGITAL PRINT=ON** Select ON (or OFF in case you had set this periodic printout before and want to stop it now) using the UP/DOWN-keys. Then press the ENT-key.
- * SET OK *** The setting is completed. Press the ENT-key to return to the '01: DIGITAL PRINT=...' display, or press the ESC-key to go to the 'SET=AUX' display; or press the MENU-key for three seconds to return to the Operation mode.

NOTE If set, this printout appears on the chart with a certain regularity. To change the interval between two printouts, see 9.4.6.

8.2.2 How to Set a Tag

The following setting enables you to set tags to be recorded instead of the usual channel numbers. Tags will appear on the display, in the periodic printout, manual printout and in the alarm printout. One tag can be set for every channel. The maximum length is seven characters.

To set a tag, proceed as follows:

MENU:

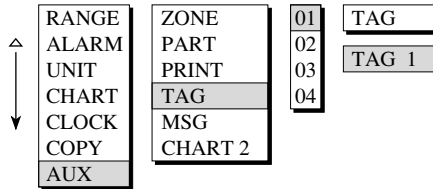

SETTING PROCEDURE:

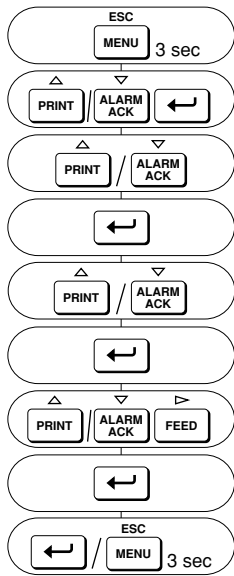

- SET=AUX** Press the MENU-key for three seconds to enter the SET mode. Select the 'SET=AUX' display using the UP/DOWN-keys, and press the ENT-key.
- MODE=TAG** Select the 'MODE=TAG' display using the UP/DOWN-keys. Then press the ENT-key.
- 01:TAG=** Select the desired channel using the UP/DOWN-keys, and press the ENT-key.
- 01:TAG= TAG 1** Enter the desired characters using the UP/DOWN and the RIGHT-keys. Then press the ENT-key. Refer to table 8.1.
- * SET OK *** The setting is completed. Press the ENT-key to return to the '01:TAG=...' display, or press the ESC-key to go to the 'SET=AUX' display; or press the MENU-key for three seconds to return to the Operation mode.

NOTE It is also necessary to set the CH/TAG-setting in the SET UP Mode to get this tag display and printout. See 9.4.1.

Table 8.1 Characters

→	A	B	C	D	E	F	G	H	I	J
△-key	K	L	M	N	O	P	Q	R	S	T
←	U	V	W	X	Y	Z	a	b	c	d
▽-key	e	f	g	h	i	j	k	l	m	n
	o	p	q	r	s	t	u	v	w	x
	y	z	0	1	2	3	4	5	6	7
	8	9	#	%	()	+	-	*	/
	.	°	μ	Ω	∪					

8.2.3 How to Set Messages

The following setting enables you to set the messages. Up to five messages can be set, each of up to 16 characters. Messages can be printed onto the chart using the keyboard, or by remote control which is optional. Note that the printing of the messages will not be done when the chart speed is faster than 1500 mm/h (pen model) or 100 mm/h (dot model) or when recording is OFF.

To set a message, proceed as follows:

MENU:

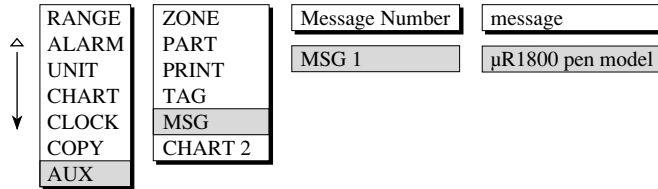

SETTING PROCEDURE:

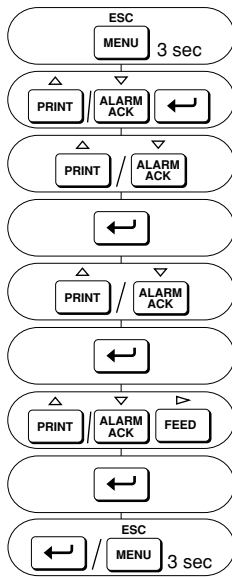

- SET=AUX** Press the MENU-key for three seconds to enter the SET mode. Select the 'SET=AUX' display using the UP/DOWN-keys, and press the ENT-key.
- MODE=MSG** Select the 'MODE=MSG' display using the UP/DOWN-keys. Then press the ENT-key.
- MESSAGE No.=MSG 1** Specify which message you want to set using the UP/DOWN-keys. Up to five messages can be set. Then press the ENT-key.
- M1=µR 1800 pen model** Enter the desired characters (up to 16) using the UP/DOWN and the RIGHT-keys. Then press the ENT-key. See table 8.2 for the characters which can be used.
- * SET OK *** The setting is completed. Press the ENT-key to return to the 'MESSAGE No.=...' display, or press the ESC-key to go to the 'SET=AUX' display; or press the MENU-key for three seconds to return to the Operation mode.

NOTE If your µR1800 is equipped with the /R1 option, and you want them to be triggered by remote control, the messages must be assigned to the /R1 terminals. See 9.8.

Table 8.2 Characters

→ △-key	A	B	C	D	E	F	G	H	I	J
	K	L	M	N	O	P	Q	R	S	T
← ▽-key	U	V	W	X	Y	Z	a	b	c	d
	e	f	g	h	i	j	k	l	m	n
	o	p	q	r	s	t	u	v	w	x
	y	z	0	1	2	3	4	5	6	7
	8	9	#	%	()	+	-	*	/
	.	°	µ	Ω	Û					

8.3 How to Set the Chart Speed Used When Change-on-alarm or Remote Control is Selected

The following describes the way to use a second chart speed which is activated by remote control or by the occurrence of alarms. This function enables you to record data in more detail following a remote control trigger or following the occurrence of an alarm. However, to use this second chart speed, it is necessary that your μ R1800 is at least equipped with the /R1 option. To be able to use the change-on-alarm function, it is necessary to have alarm output relays installed as well (option /A1, 2 or 3). If your μ R1800 is not equipped with the /R1 option, data entry will be ignored. This second chart speed will stay in effect until the remote control status changes back again, or until the alarm turns OFF. The initial value is 25 mm/h. To set this chart speed, proceed as follows:

MENU:

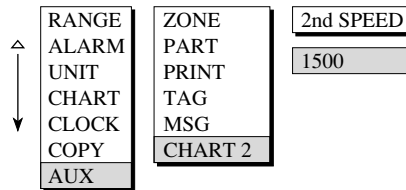

SETTING PROCEDURE:

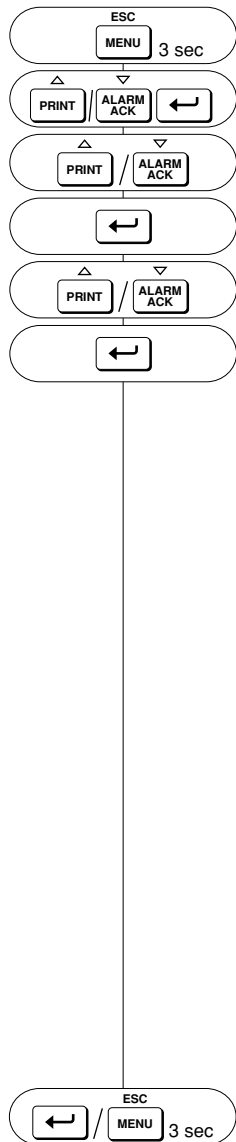

SET=AUX

Press the MENU-key for three seconds to enter the SET mode. Select the 'SET=AUX' display using the UP/DOWN-keys, and press the ENT-key.

MODE=CHART 2

Select the 'MODE=CHART2' display using the UP/DOWN-keys. Then press the ENT-key.

2nd SPEED=1500 mm/h

In case of the pen model, select the desired chart speed using the UP/DOWN-keys. You can select any of the below shown chart speeds. Then press the ENT-key.

In case of the dot model, set the desired chart speed using the UP/DOWN and RIGHT-keys, and press the ENT-key.

Table 8.3 Chart Speeds in mm/h (pen model)

5	6	8	9	10	12	15	16	18	20
24	25	30	32	36	40	45	48	50	54
60	64	72	75	80	90	96	100	120	125
135	150	160	180	200	225	240	250	270	300
320	360	375	400	450	480	500	540	600	675
720	750	800	900	960	1000	1080	1200	1350	1440
1500	1600	1800	2000	2160	2250	2400	2700	2880	3000
3600	4000	4320	4500	4800	5400	6000	7200	8000	9000
10800	12000								

Note that the interval between digital printouts will change according to the new chart speed. Therefore check in table 8.4 that all the printouts will be printed as expected.

Table 8.4 Chart Speeds for which Printouts will not be performed

Model	Periodic Printout	Alarm Printout/Recording Start/Message Printout/Chart Speed Change/Channel/Tag (dot model only)
pen	5 to 9 mm/h	1600 to 12000 mm/h
6/12 dot model	1 to 9 mm/h, 101 to 1500 mm/h	100 to 1500 mm/h
18/24 dot model	1 to 9 mm/h, 51 to 1500 mm/h	51 to 1500 mm/h

* SET OK *

The setting is completed. Press the ENT-key to return to the '2nd_SPEED=...mm/h' display, or press the ESC-key to go to the 'SET=AUX' display; or press the MENU-key for three seconds to return to the Operation mode.

Chapter 9 CHANGING INITIAL SETTINGS

This chapter describes how to change initial settings. These settings are entered during the manufacturing of the recorder and seldom need to be changed.

See 6.3.3 for flow chart.

Note that while you are changing any of the following settings, recording cannot be performed and alarms will not be detected.

They are grouped into

- 9.1 How to change initial settings for the alarm function
- 9.2 How to change initial settings for the input
- 9.3 How to change initial settings for analog recording
- 9.4 How to change initial settings for digital printouts
- 9.5 How to select the type of bargraph
- 9.6 How to change the temperature unit
- 9.7 How to initialize settings
- 9.8 How to change initial settings for the REMOTE option
- 9.9 How to select to trigger the recording to start/stop
- 9.10 How to change key-lock settings

9.1 How to Change Initial Settings for the Alarm Function

This paragraph describes how to change initial settings for the alarm function.

- 9.1.1 How to select the reflash function ON/OFF (initial value = 'OFF')
- 9.1.2 How to select the output relay to be of AND/OR type (initial value = 'NONE')
- 9.1.3 How to select the output relay to be energizing/de-energizing on alarm (initial value = 'ENERG')
- 9.1.4 How to select the alarm output relay to be of HOLD/NON-HOLD type (initial value = 'NONHOLD')
- 9.1.5 How to select the alarm indicator to be of HOLD/NON-HOLD type (initial value = 'NONHOLD')
- 9.1.6 How to set the sampling interval for rate-of-change alarms (initial value = '01')
- 9.1.7 How to select alarm hysteresis ON/OFF (initial value = 'ON')

CAUTION

When exiting SETUP MODE using "SETUP=END" and "STORE" statement. Do-not turn the power OFF until the Recorder has returned to the OPERATION MODE. Calibration data might be affected.

9.1.1 How to Select the Reflash Function ON/OFF

Reflash is a function to indicate repeating alarm occurrences among a group of alarms sharing the same output relay. When the optional alarm output relays are not installed, data entry will be ignored. Note that only I01 to I03 (which should be assigned in the alarm setting also) can be used for the reflash function. The initial value is 'OFF'.

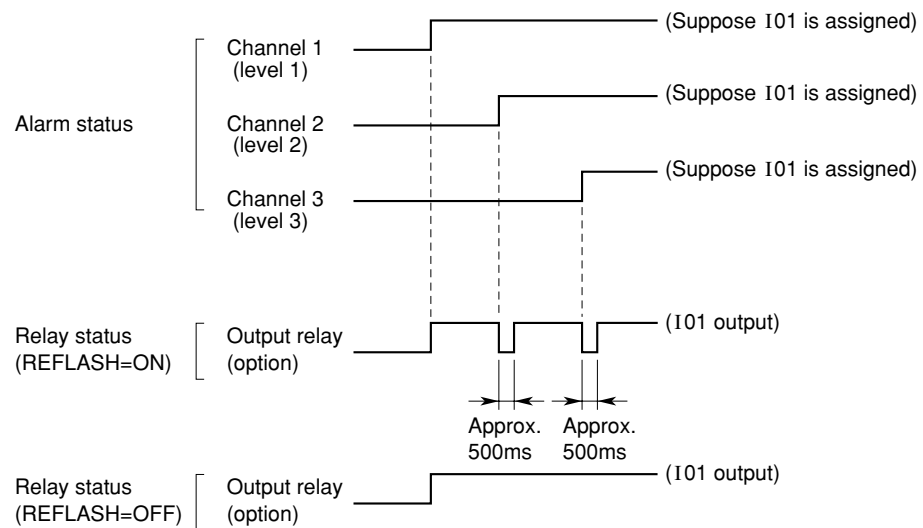

Figure 9.1

SETTING PROCEDURE:

Enter the SET UP Mode by turning 'ON' the power while pressing and holding the ENT-key until the SET UP display appears.

Use the UP/DOWN-keys to select the display 'SETUP=ALARM'. Press the ENT-key.

The display 'REFLASH=...' will appear. Select ON or OFF. Press the ENT-key.

The reflash setting has been completed, but has not been stored yet. Before you can adjust other settings in the SET UP Mode, you have to finish the alarm settings until the '*ALARM SET*' display appears.

Before leaving the SET UP Mode, you have to store your new settings. Proceed with the alarm settings until the display '*ALARM SET*' appears. Press the ESC-key to return to the 'SETUP=ALARM' display and then select the 'SETUP=END' display. Press the ENT-key. Select 'END=STORE' to keep your new settings or 'END=ABORT' and press the ENT-key. After a few seconds, the Operation Mode will appear.

NOTE

When I01 to I03 are used for the reflash function, they cannot be used for the AND function, see 9.1.2.

I01 to I03 will be exclusively used for the reflash function, regardless of the number of alarm output relays.

9.1.2 How to Select the Output Relay to be of AND/OR Type

The (optional) output relays can be specified to be AND or OR type, which is necessary when a group of alarms shares the same output relay. The initial value is 'NONE', which means that all relays are OR output. When the optional alarm output relays are not installed, data entry will be ignored. Note that when you set I01 to I03 to reflash, only I04 to I24 can be specified for AND/OR.

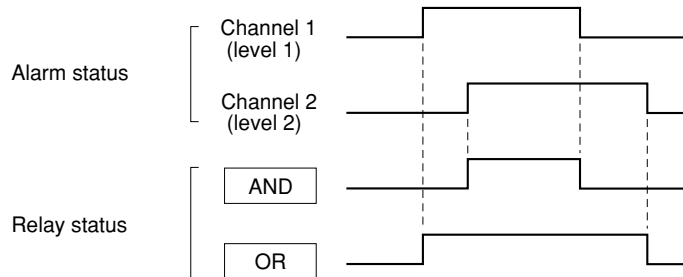

Figure 9.2

SETTING PROCEDURE:

Enter the SET UP Mode by turning 'ON' the power while pressing and holding the ENT-key until the SET UP display appears.

Use the UP/DOWN-keys to select the display 'SETUP=ALARM'. Press the ENT-key.

Press the ENT-key until the display 'AND=...' appears. Select which relays must be of AND type. Depending on your options, you can specify up to 24 relays (I01 to I24). Relays which are not selected will be of OR type. 'NONE' means that all relays are OR output. After selection, press the ENT-key. Note that I01 will always be displayed at the left side of the display.

The AND/OR setting has been completed, but has not been stored yet. Before you can adjust other settings in the SET UP Mode, you have to finish the alarm settings until the '*ALARM SET*' display appears.

Before leaving the SET UP Mode, you have to store your new settings. Proceed with the alarm settings until the display '*ALARM SET*' appears. Press the ESC-key to return to the 'SETUP=ALARM' display and then select the 'SETUP=END' display. Press the ENT-key. Select 'END=STORE' to keep your new settings or 'END=ABORT' and press the ENT-key. After a few seconds, the Operation Mode will appear.

9.1.3 How to Select the Output Relay to be Energizing/De-energizing on Alarm

The alarm output relays can be selected to be energizing or de-energizing on alarm. Using de-energizing, alarm output relay is activated either when an alarm occurs, or when power off occurs (common for all relays). This enables simple monitoring of power supply.

The initial value is 'ENERG'.

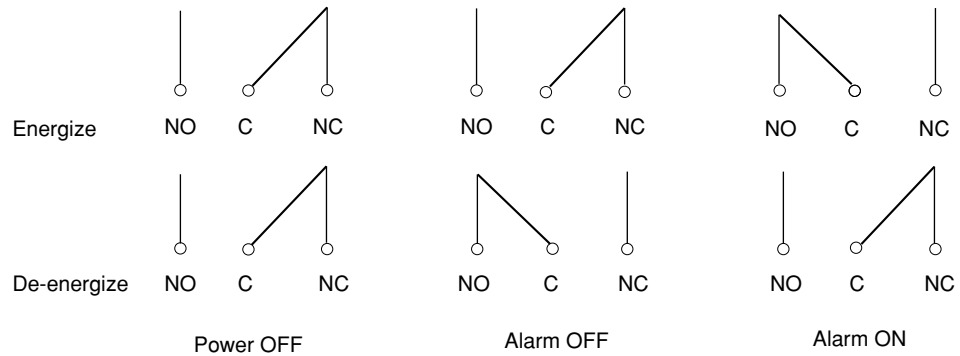

Figure 9.3

SETTING PROCEDURE:

Enter the SET UP Mode by turning 'ON' the power while pressing and holding the ENT-key until the SET UP display appears.

Use the UP/DOWN-keys to select the display 'SETUP=ALARM'. Press the ENT-key.

Press the ENT-key until the display 'ALARM=ENERG' appears. Select energize (ENERG) or de-energize (DE_EN). After selection, press the ENT-key.

The energize/de-energize setting has been completed, but has not been stored yet. Before you can adjust other settings in the SET UP Mode, you have to finish the alarm settings until the '*ALARM SET*' display appears.

Before leaving the SET UP Mode, you have to store your new settings. Proceed with the alarm settings until the display '*ALARM SET*' appears. Press the ESC-key to return to the 'SETUP=ALARM' display and then select the 'SETUP=END' display. Press the ENT-key. Select 'END=STORE' to keep your new settings or 'END=ABORT' and press the ENT-key. After a few seconds, the Operation Mode will appear.

9.1.4 How to Select the Alarm Output Relay to be of HOLD/NON-HOLD Type

You can select whether or not to hold alarm output relays until reset.
The initial value is 'NON-HOLD', and common for all relays.

NON-HOLD:

Output relay turns ON and OFF together with alarm.

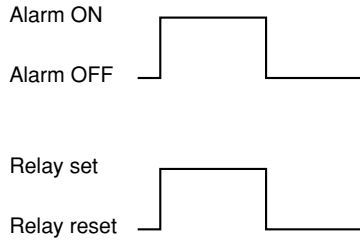

HOLD:

Once turned ON, the alarm output relay remains ON even if the alarm turns OFF.
The relay is turned OFF by pressing the ACK-key.

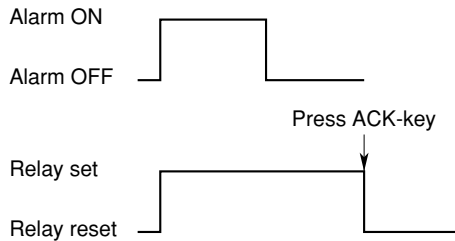

SETTING PROCEDURE:

Enter the SET UP Mode by turning 'ON' the power while pressing and holding the ENT-key until the SET UP display appears.

Use the UP/DOWN-keys to select the display 'SETUP=ALARM'. Press the ENT-key.

Press the ENT-key until the display 'RLY=NONHOLD' appears. Select HOLD or NONHOLD. After selection, press the ENT-key.

The relay HOLD/NONHOLD setting has been completed, but has not been stored yet. Before you can adjust other settings in the SET UP Mode, you have to finish the alarm settings until the '*ALARM SET*' display appears.

Before leaving the SET UP Mode, you have to store your new settings. Proceed with the alarm settings until the display '*ALARM SET*' appears. Press the ESC-key to return to the 'SETUP=ALARM' display and then select the 'SETUP=END' display. Press the ENT-key. Select 'END=STORE' to keep your new settings or 'END=ABORT' and press the ENT-key. After a few seconds, the Operation Mode will appear.

9.1.5 How to Select the Alarm Indicator to be of HOLD/NON-HOLD Type

You can select whether or not to hold the indicator until reset.
The initial value is 'NON-HOLD', and common for all alarms.

NON-HOLD:

Indicator turns ON and OFF together with alarm.

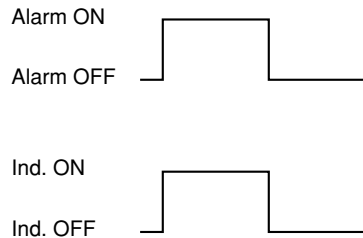

HOLD:

Once flashing, the indicator remains flashing even if the alarm turns OFF. The indicator shows the current alarm status by pressing the ACK-key (in alarm = ON, alarm recovered = OFF).

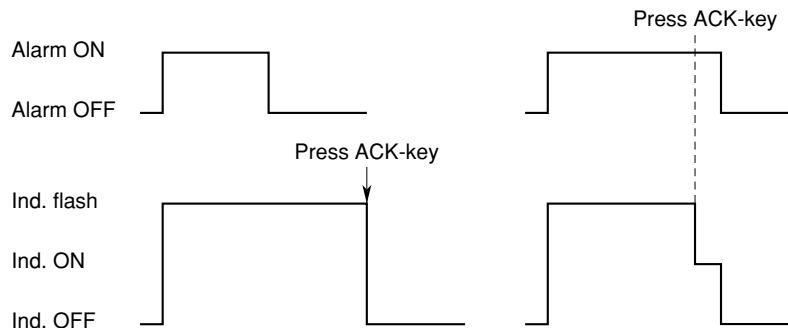

SETTING PROCEDURE:

Enter the SET UP Mode by turning 'ON' the power while pressing and holding the ENT-key until the SET UP display appears.

Use the UP/DOWN-keys to select the display 'SETUP=ALARM'. Press the ENT-key.

Press the ENT-key until the display 'IND=NONHOLD' appears. Select HOLD or NONHOLD. After selection, press the ENT-key.

The indicator HOLD/NONHOLD setting has been completed, but has not been stored yet. Before you can adjust other settings in the SET UP Mode, you have to finish the alarm settings until the '*ALARM SET*' display appears.

Before leaving the SET UP Mode, you have to store your new settings. Proceed with the alarm settings until the display '*ALARM SET*' appears. Press the ESC-key to return to the 'SETUP=ALARM' display and then select the 'SETUP=END' display. Press the ENT-key. Select 'END=STORE' to keep your new settings or 'END=ABORT' and press the ENT-key. After a few seconds, the Operation Mode will appear.

9.1.6 How to Set the Sampling Interval for Rate-of-change Alarms

You can change the sampling interval for rate-of-change alarms by the following setting (common for all alarms).

The initial value is '01' sample (the actual time depends on the model and A/D frequency; see also table 9.1 on page 9-9).

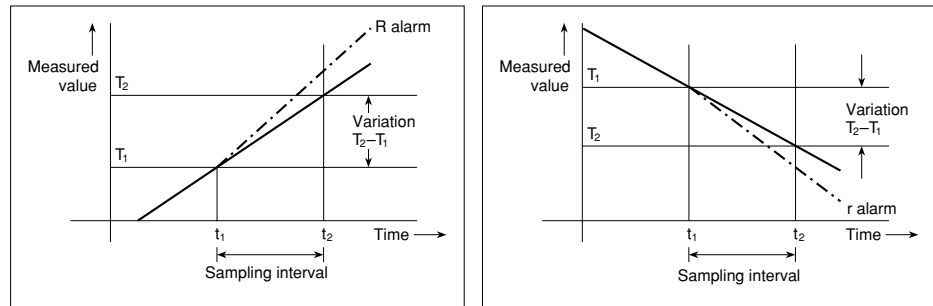

Figure 9.4

If you want to change the sampling interval for rate-of-change on **increasing** signal:

SETTING PROCEDURE:

Enter the SET UP Mode by turning 'ON' the power while pressing and holding the ENT-key until the SET UP display appears.

Use the UP/DOWN-keys to select the display 'SETUP=ALARM'. Press the ENT-key.

Press the ENT-key until the display 'R_TIME=1' appears. Select the sampling interval (min. is 1 sample interval, max. is 15 sample interval). After selection, press the ENT-key.

The setting has been completed, but has not been stored yet.

Before leaving the SET UP Mode, you have to store your new settings. Proceed with the alarm settings until the display '*ALARM SET*' appears. Press the ESC-key to return to the 'SETUP=ALARM' display and then select the 'SETUP=END' display. Press the ENT-key. Select 'END=STORE' to keep your new settings or 'END=ABORT' and press the ENT-key. After a few seconds, the Operation Mode will appear.

If you want to change the sampling interval for rate-of-change on **decreasing** signal:

SETTING PROCEDURE:

Enter the SET UP Mode by turning 'ON' the power while pressing and holding the ENT-key until the SET UP display appears.

Use the UP/DOWN-keys to select the display 'SETUP=ALARM'. Press the ENT-key.

Press the ENT-key until the display 'r_TIME=1' appears. Select the sampling interval (min. is 1 sample interval, max. is 15 sample interval). After selection, press the ENT-key.

The setting has been completed, but has not been stored yet.

Before leaving the SET UP Mode, you have to store your new settings. Proceed with the alarm settings until the display '*ALARM SET*' appears. Press the ESC-key to return to the 'SETUP=ALARM' display and then select the 'SETUP=END' display. Press the ENT-key. Select 'END=STORE' to keep your new settings or 'END=ABORT' and press the ENT-key. After a few seconds, the Operation Mode will appear.

9.1.7 How to Select Alarm Hysteresis ON/OFF

The alarm hysteresis is the difference between the levels of alarm occurrence and reset. You can choose between two levels of hysteresis: 0% (=OFF) and approx. 0.5% of the recording span (=ON) (common for all alarms). The initial value is 'ON'.

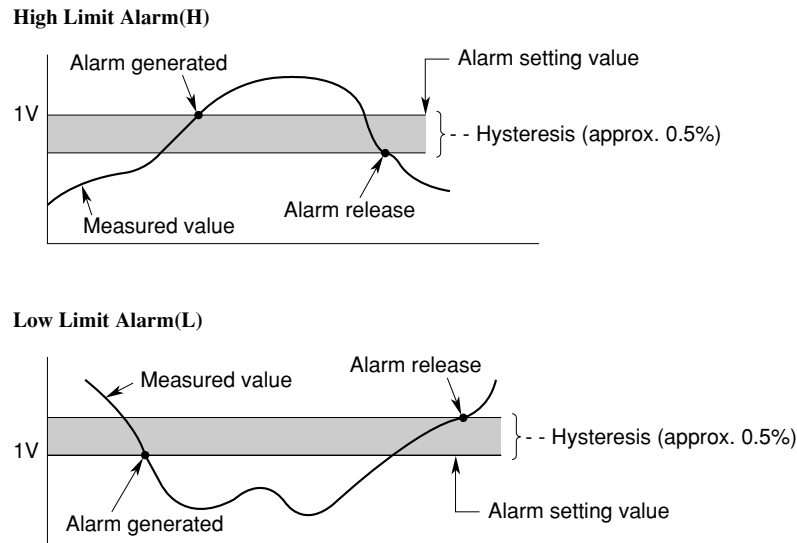

Figure 9.5

SETTING PROCEDURE:

Enter the SET UP Mode by turning 'ON' the power while pressing and holding the ENT-key until the SET UP display appears.

Use the UP/DOWN-keys to select the display 'SETUP=ALARM'. Press the ENT-key.

Press the ENT-key until the display 'ALM_HYS=ON' appears. Select ON or OFF. After selection, press the ENT-key. The display '*ALARM SET*' will appear.

The alarm hysteresis setting has been completed, but has not been stored yet. You can now adjust other settings in the SET UP Mode, by using the ESC-key.

Before leaving the SET UP Mode, you have to store your new settings. Press the ESC-key to return to the 'SETUP=ALARM' display and then select the 'SETUP=END' display.

Press the ENT-key. Select 'END=STORE' to keep your new settings or 'END=ABORT' and press the ENT-key. After a few seconds, the Operation Mode will appear.

NOTE Hysteresis setting is only valid for High and Low alarms. Hysteresis setting for rate-of-change alarms and difference alarms will be ignored.

9.2 How to Change Initial Settings for the Input

This paragraph describes how to change initial settings for the input.

- 9.2.1 How to set the A/D integration time (initial value = 'AUTO' for pen model, and '100 ms' for dot model)
- 9.2.2 How to set upscale/downscale TC burnout (initial value = 'UP', 'OFF')
- 9.2.3 How to set internal or external RJC (initial value = 'INT')
- 9.2.4 How to select the input filter (initial value = 'OFF') (pen model)
- 9.2.5 How to select a moving average (initial value = 'OFF') (dot model)

9.2.1 How to Set the A/D Integration Time

The purpose of the following setting is to specify which A/D integration time will be used. Depending on the power supply, the integration time will affect the ability of noise rejection and therefore the recording.

In case of the pen model

If the power supply of the recorder and of the measuring object are the same, the effect of noise will be automatically minimized and the (initial) value of AUTO is the recommended one.

If the power supplies are different, you should select from 50Hz or 60Hz integration time. The choice depends on the power supply of the instrument with the highest noise level.

There are three possibilities:

- AUTO: integration time depends on the power supply of the recorder. However, in case of the /P1 model, the integration time is fixed to 50Hz.
- 50Hz
- 60Hz.

The initial value is 'AUTO'.

In case of the dot model

The initial value is 100 ms, and this setting should only be changed when required because of specific optional functions. For details, see the option manuals.

There are four possibilities:

- AUTO: integration time depends on the power supply of the recorder. However, in case of the /P1 model, the integration time is fixed to 50Hz.
- 50Hz
- 60Hz
- 100 ms.

The initial value is '100 ms'.

SETTING PROCEDURE:

Enter the SET UP Mode by turning 'ON' the power while pressing and holding the ENT-key until the SET UP display appears.

Use the UP/DOWN-keys to select the display 'SETUP=INTG'. Press the ENT-key.

Select AUTO, 50Hz, 60Hz or 100ms according to your situation using the UP/DOWN-keys.

Then press the ENT-key. The display '*INTG SET*' will appear. Note that the sampling time will differ according to this setting. See table 9.1.

The A/D integration time setting has been completed, but has not been stored yet. You can now adjust other settings in the SET UP Mode, by using the ESC-key.

Before leaving the SET UP Mode, you have to store your new settings. Press the ESC-key to return to the 'SETUP=INTG' display and then select the 'SETUP=END' display.

Press the ENT-key. Select 'END=STORE' to keep your new settings or 'END=ABORT' and press the ENT-key. After a few seconds, the Operation Mode will appear.

Table 9.1 Sampling Time

A/D Frequency	100ms	50/60Hz
pen model	—	125ms
6 dot model	2.5s	2.5s
12 dot model	5s	2.5s
18 dot model	10s	2.5s
24 dot model	10s	2.5s

9.2.2 How to Set Upscale/Downscale TC Burnout

The purpose of the following setting is to specify where the pens will move in case of a TC-burnout. You can choose from moving to the right (UP) or to the left (DOWN). This is common for every channel. You can select ON or OFF for each channel. The initial value is 'UP', and 'OFF' for every channel.

SETTING PROCEDURE:

Enter the SET UP Mode by turning 'ON' the power while pressing and holding the ENT-key until the SET UP display appears.

Use the UP/DOWN-keys to select the display 'SETUP=B.OUT'. Press the ENT-key.

Select UP or DOWN using the UP/DOWN-keys. Press the ENT-key.

This burnout processing is ON/OFF selectable per channel. Select the channel No. for which you want to specify this burnout processing. Then press the ENT-key.

Select ON or OFF. Then press the ENT-key. The display '*B.OUT SET*' will appear.

The burnout setting has been completed, but has not been stored yet. You can now adjust other settings in the SET UP Mode, by pressing the ESC-key.

Before leaving the SET UP Mode, you have to store your new settings. Press the ESC-key to return to the 'SETUP=B.OUT' display and then select the 'SETUP=END' display.

Press the ENT-key. Select 'END=STORE' to keep your new settings or 'END=ABORT' and press the ENT-key. After a few seconds, the Operation Mode will appear.

9.2.3 How to Set Internal or External RJC

The purpose of the following setting is to select whether internal or external reference junction compensation values are used.

In the case of INTernal, the reference junction compensation is based on the internal RJC circuit.

In the case of EXTernal, the reference junction compensation is based on an external voltage input.

The initial value is 'INT'.

SETTING PROCEDURE:

Enter the SET UP Mode by turning 'ON' the power while pressing and holding the ENT-key until the SET UP display appears.

Use the UP/DOWN-keys to select the display 'SETUP=RJC'. Press the ENT-key.

Select the channel No. for which you want to specify this RJC setting. Then press the ENT-key.

Select INT or EXT using the UP/DOWN-keys. Press the ENT-key.

If you selected INT:

The RJC setting has been completed, but has not been stored yet. The display '*RJC SET*' will appear. You can now adjust other settings in the SET UP Mode, by pressing the ESC-key.

Before leaving the SET UP Mode, you have to store your new settings. Press the ESC-key to return to the 'SETUP=RJC' display and then select the 'SETUP=END' display.

Press the ENT-key. Select 'END=STORE' to keep your new settings or 'END=ABORT' and press the ENT-key. After a few seconds, the Operation Mode will appear.

If you selected EXT:

Set the input voltage to use for reference junction using the UP/DOWN-keys (must be within $-20000\mu\text{V}$ to $+20000\mu\text{V}$ range, initial value is $0\mu\text{V}$). Then press the ENT-key.

The RJC setting has been completed, but has not been stored yet. The display '*RJC SET*' will appear. You can now adjust other settings in the SET UP Mode, by pressing the ESC-key.

Before leaving the SET UP Mode, you have to store your new settings. Press the ESC-key to return to the 'SETUP=RJC' display and then select the 'SETUP=END' display.

Press the ENT-key. Select 'END=STORE' to keep your new settings or 'END=ABORT' and press the ENT-key. After a few seconds, the Operation Mode will appear.

9.2.4 How to Select the Input Filter (Pen Model)

Noise in the measured signal can be suppressed in the final measurement by using an input filter. This is sometimes referred to as signal damping. The purpose of this setting is to select for each channel whether or not to use a filter, and if so, to select a time constant of damping.

A filter works as follows:

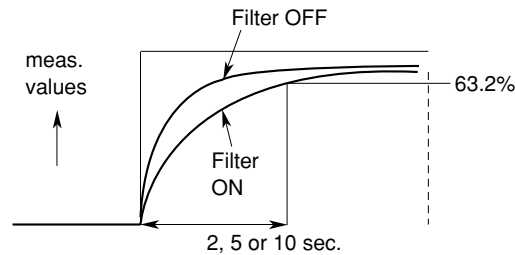

If a filter is used, the response time can be selected from 2, 5 or 10 seconds.

You can choose from three filters:

- 2 seconds
- 5 seconds
- 10 seconds.

The initial value is 'OFF'.

SETTING PROCEDURE:

Enter the SET UP Mode by turning 'ON' the power while pressing and holding the ENT-key until the SET UP display appears.

Use the UP/DOWN-keys to select the display 'SETUP=FILTR'. Press the ENT-key.

Select the channel No. for which you want to specify a filter. Then press the ENT-key.

Select the type of filter you want to use. You can choose from no filter (OFF), 2 seconds, 5 seconds or 10 seconds. Press the ENT-key. The display '*FILTR SET*' will appear.

The filter setting has been completed, but has not been stored yet. Press the ENT-key to continue the setting for other channels or the ESC-key to adjust other settings in the SET UP Mode.

Before leaving the SET UP Mode, you have to store your new settings. Press the ESC-key to return to the 'SETUP=FILTR' display and then select the 'SETUP=END' display.

Press the ENT-key. Select 'END=STORE' to keep your new settings or 'END=ABORT' and press the ENT-key. After a few seconds, the Operation Mode will appear.

9.2.5 How to Select a Moving Average (Dot Model)

Noise in the measured signal can be suppressed in the final measurement by computing a moving average. It is possible to record a moving average calculated over the previous X samples, selectable from the previous 2 samples up to the previous 16 samples. The purpose of the following setting is to select for each channel whether or not to compute a moving average, and if so, over how many samples.

The initial value is 'OFF'.

Example: (let us assume a moving average over 5 samples is selected)

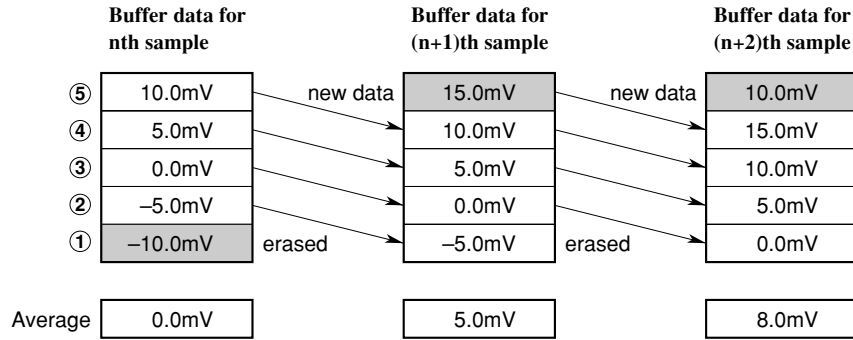

SETTING PROCEDURE:

Enter the SET UP Mode by turning 'ON' the power while pressing and holding the ENT-key until the SET UP display appears.

Use the UP/DOWN-keys to select the display 'SETUP=M_AVE'. Press the ENT-key.

Select the channel No. for which you want to compute a moving average. Then press the ENT-key.

Select the number of samples. You can choose from 2 samples, 3 samples, ... up to 16 samples. Of course you can also select OFF. Press the ENT-key. The display '*M_AVE SET*' will appear.

The moving average setting has been completed, but has not been stored yet. Press the ENT-key to continue the setting for other channels or the ESC-key to adjust other settings in the SET UP Mode.

Before leaving the SET UP Mode, you have to store your new settings. Press the ESC-key to return to the 'SETUP=M_AVE' display and then select the 'SETUP=END' display.

Press the ENT-key. Select 'END=STORE' to keep your new settings or 'END=ABORT' and press the ENT-key. After a few seconds, the Operation Mode will appear.

9.3 How to Change Initial Settings for Analog Recording

This paragraph describes how to change initial settings for analog recording.

9.3.1 How to select pen offset compensation ON/OFF (initial value = 'OFF') (pen model)

9.3.2 How to assign different colors to channels (dot model)

Related settings concern the way to adjust the position of pens and printer carriage, which is described in chapter 11 (see 11.3 and 11.4).

9.3.1 How to Select Pen Offset Compensation ON/OFF (Pen Model)

The POC function eliminates deviation (phase difference) between the pens on the time axis. Figure 9.6 shows a side view of the recording status for the 2 pen model (3 & 4 pen models are similar).

The initial value is 'OFF'.

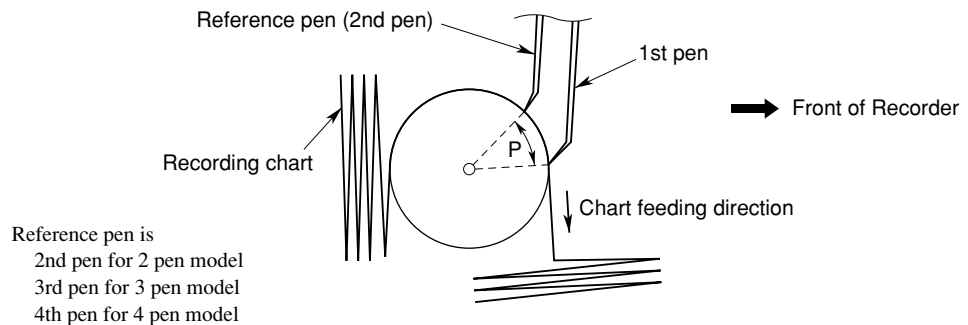

Figure 9.6 Side View of Recording Status

Figure 9.6 shows that, in any pen recorder (in order to prevent collision between pens) the pens must be offset by a distance p . Therefore, points recorded at the same time are separated on the time axis.

In the case of Pen Offset Compensation, a delay memory is used to store measurement data, equivalent to the time offset p of the pens (other than the reference pen).

The pens will start to record these stored data when the chart is fed by the amount of p (time offset).

NOTE Immediately after the recording has been started, only the reference pen operates normally. The other pens might not seem to operate correctly, but this is due to the time offset.

When you stop the recording, the chart will stop and therefore data stored in the delay memory will not be recorded anymore. Therefore, these data will be lost.

Pen Offset Compensation is meaningless for the 1 pen model. Therefore POC setting will be ignored for the 1 pen model.

Note that an asterisk will be printed in the periodic printout when POC is 'ON'.

SETTING PROCEDURE:

Enter the SET UP Mode by turning 'ON' the power while pressing and holding the ENT-key until the SET UP display appears.

Use the UP/DOWN-keys to select the display 'SETUP=POC'. Press the ENT-key.

Select ON or OFF. Then press the ENT-key. The display '*POC SET*' will appear.

The POC setting has been completed, but has not been stored yet. You can now adjust other settings in the SET UP Mode, by using the ESC-key.

Before leaving the SET UP Mode, you have to store your new settings. Press the ESC-key to return to the 'SETUP=POC' display and then select the 'SETUP=END' display.

Press the ENT-key. Select 'END=STORE' to keep your new settings or 'END=ABORT' and press the ENT-key. After a few seconds, the Operation Mode will appear.

9.3.2 How to Assign Different Colors to Channels (Dot Model)

You can assign any of the six provided colors to any channel. The initial setting is as follows:

ch.1, 7, 13, 19 = purple
ch.2, 8, 14, 20 = red
ch.3, 9, 15, 21 = green
ch.4, 10, 16, 22 = blue
ch.5, 11, 17, 23 = brown
ch.6, 12, 18, 24 = black

SETTING PROCEDURE:

Enter the SET UP Mode by turning 'ON' the power while pressing and holding the ENT-key until the SET UP display appears.

Use the UP/DOWN-keys to select the display 'SETUP=COLOR'. Press the ENT-key.

Select the channel No. for which you want to change a color. Then press the ENT-key.

Select the color. Then press the ENT-key. The display '*COLOR SET*' will appear.

The color setting has been completed, but has not been stored yet. Press the ENT-key to set the color for other channels or press the ESC-key to adjust other settings in the SET UP Mode.

Before leaving the SET UP Mode, you have to store your new settings. Press the ESC-key to return to the 'SETUP=COLOR' display and then select the 'SETUP=END' display.

Press the ENT-key. Select 'END=STORE' to keep your new settings or 'END=ABORT' and press the ENT-key. After a few seconds, the Operation Mode will appear.

9.4 How to Change Initial Settings for Digital Printouts

This paragraph describes how to change initial settings for digital printouts.

(Note that the selection to trigger the recording to start/stop is explained in 9.9)

9.4.1 How to select channel numbers or tag printout (initial value = 'CH')

9.4.2 How to select scales printout ON/OFF (initial value = 'ON')

9.4.3 How to select the new chart speed printout ON/OFF (initial value = 'OFF')

9.4.4 How to select the record start time printout ON/OFF (initial value = 'OFF')

9.4.5 How to select alarm settings and alarm printout (initial value = 'ON1')

9.4.6 How to select to trigger the periodic printout (initial value = 'INT', 'AUTO')

9.4.1 How to Select Channel Numbers or Tag Printout

You can select channel numbers or tags printed out in the periodic, manual, channel and alarm printout. This also results in displaying tags or channel numbers on the display. The initial value is 'CH', and this setting is common for all channels.

SETTING PROCEDURE:

Enter the SET UP Mode by turning 'ON' the power while pressing and holding the ENT-key until the SET UP display appears.

Use the UP/DOWN-keys to select the display 'SETUP=RCD'. Press the ENT-key.

Press the ENT-key until the display 'CH/TAG=...' will appear. Select CH or TAG. Press the ENT-key.

This setting has been completed, but has not been stored yet. Before you can adjust other settings in the SET UP Mode, you have to finish the recording settings until the '*RCD SET*' display appears.

Before leaving the SET UP Mode, you have to store your new settings. Proceed with the recording settings until the display '*RCD SET*' appears. Press the ESC-key to return to the 'SETUP=RCD' display and then select the 'SETUP=END' display. Press the ENT-key. Select 'END=STORE' to keep your new settings or 'END=ABORT' and press the ENT-key. After a few seconds, the Operation Mode will appear.

9.4.2 How to Select Scales Printout ON/OFF

You can select to get scales printed on the chart.

Note that the scales will not be printed when the chart speed exceeds 1500 mm/h. (pen model) or 100 mm/h. (dot model).

The initial value is 'ON'.

SETTING PROCEDURE:

Enter the SET UP Mode by turning 'ON' the power while pressing and holding the ENT-key until the SET UP display appears.

Use the UP/DOWN-keys to select the display 'SETUP=RCD'. Press the ENT-key.

Press the ENT-key until the display 'SCL_PR=...' will appear. Select ON or OFF. Press the ENT-key.

This setting has been completed, but has not been stored yet. Before you can adjust other settings in the SET UP Mode, you have to finish the recording settings until the '*RCD SET*' display appears.

Before leaving the SET UP Mode, you have to store your new settings. Proceed with the recording settings until the display '*RCD SET*' appears. Press the ESC-key to return to the 'SETUP=RCD' display and then select the 'SETUP=END' display. Press the ENT-key. Select 'END=STORE' to keep your new settings or 'END=ABORT' and press the ENT-key. After a few seconds, the Operation Mode will appear.

9.4.3 How to Select the New Chart Speed Printout ON/OFF

You can select the new chart speed printed on the chart when the chart speed changes. Note that the chart speed will not be printed when the chart speed exceeds 1500 mm/h. (pen model) or 100 mm/h. (dot model).
The initial value is 'OFF'.

SETTING PROCEDURE:

Enter the SET UP Mode by turning 'ON' the power while pressing and holding the ENT-key until the SET UP display appears.

Use the UP/DOWN-keys to select the display 'SETUP=RCD'. Press the ENT-key.

Press the ENT-key until the display 'SPD_PR=...' will appear. Select ON or OFF. Press the ENT-key.

This setting has been completed, but has not been stored yet. Before you can adjust other settings in the SET UP Mode, you have to finish the recording settings until the '*RCD SET*' display appears.

Before leaving the SET UP Mode, you have to store your new settings. Proceed with the recording settings until the '*RCD SET*' display appears. Press the ESC-key to return to the 'SETUP=RCD' display and then select the 'SETUP=END' display. Press the ENT-key. Select 'END=STORE' to keep your new settings or 'END=ABORT' and press the ENT-key. After a few seconds, the Operation Mode will appear.

9.4.4 How to Select the Record Start Time Printout ON/OFF

You can select to get the time printed on the chart when the recording starts. Note that the time will not be printed when the chart speed exceeds 1500 mm/h. (pen model) or 100 mm/h. (dot model).
The initial value is 'OFF'.

SETTING PROCEDURE:

Enter the SET UP Mode by turning 'ON' the power while pressing and holding the ENT-key until the SET UP display appears.

Use the UP/DOWN-keys to select the display 'SETUP=RCD'. Press the ENT-key.

Press the ENT-key until the display 'RCD_PR=...' will appear. Select ON or OFF. Press the ENT-key.

This setting has been completed, but has not been stored yet. Before you can adjust other settings in the SET UP Mode, you have to finish the recording settings until the '*RCD SET*' display appears.

Before leaving the SET UP Mode, you have to store your new settings. Proceed with the recording settings until the '*RCD SET*' display appears. Press the ESC-key to return to the 'SETUP=RCD' display and then select the 'SETUP=END' display. Press the ENT-key. Select 'END=STORE' to keep your new settings or 'END=ABORT' and press the ENT-key. After a few seconds, the Operation Mode will appear.

9.4.5 How to Select Alarm Settings and Alarm Printout

When alarms occur, the channel number, type of alarm and ON/OFF time can be printed on the right side of the chart. It is selectable to get the ON/OFF time of alarms (ON1), the ON time only (ON2) or to get no printout (OFF). Note that alarms will not be printed when the chart speed exceeds 1500 mm/h. (pen model) or 100 mm/h. (dot model).

The initial value is 'ON1', and this setting is common for all channels.

SETTING PROCEDURE:

Enter the SET UP Mode by turning 'ON' the power while pressing and holding the ENT-key until the SET UP display appears.

Use the UP/DOWN-keys to select the display 'SETUP=RCD'. Press the ENT-key.

Press the ENT-key until the display 'ALM_PR=...' will appear. Select ON1 (ON/OFF time of alarms will be printed), ON2 (ON time only will be recorded) or OFF (no alarm will be recorded). Press the ENT-key.

This setting has been completed, but has not been stored yet. Before you can adjust other settings in the SET UP Mode, you have to finish the recording settings until the '*RCD SET*' display appears.

Before leaving the SET UP Mode, you have to store your new settings. Proceed with the recording settings until the '*RCD SET*' display appears. Press the ESC-key to return to the 'SETUP=RCD' display and then select the 'SETUP=END' display. Press the ENT-key. Select 'END=STORE' to keep your new settings or 'END=ABORT' and press the ENT-key. After a few seconds, the Operation Mode will appear.

9.4.6 How to Select to Trigger the Periodic Printout

The selections are structured as follows:

The first selection is to specify whether the periodic printout should be triggered internally or externally.

If you select INTernal, you should set the reference time of the first periodic printout (initial value is '00:00'). Next you have to specify which interval should be used between two periodic printouts. You can choose from AUTO, which means that the interval depends on the chart speed, and MAN, which means that you can specify the interval yourself.

If you select EXTernal, you should also specify this at the settings for the REMOTE option (see 9.8) and the setting is completed.

The initial value is 'INT', 'AUTO'.

SETTING PROCEDURE:

Enter the SET UP Mode by turning 'ON' the power while pressing and holding the ENT-key until the SET UP display appears.

Use the UP/DOWN-keys to select the display 'SETUP=RCD'. Press the ENT-key.

Press the ENT-key until the display 'DGT_PR=...' will appear. Select INT (in the case of internal triggering) or EXT (in the case of external triggering). Press the ENT-key.

If you selected INT:

The display 'START=00:00' will appear. Specify the reference time of the first periodic printout using the UP/DOWN-keys. Press the ENT-key. Note that you cannot specify minutes.

Specify which interval between the periodic printouts you prefer. Choose from AUTO (and the interval depends on the chart speed) or MAN (and you can specify the interval yourself). Then press the ENT-key. Note that in case of AUTO, the relation between the chart speed and the printing intervals of periodic printouts will be as shown in the tables below.

Pen Model

Chart Speed	Printing Interval of Periodic Printout
5 to 9 mm/h	no printout
10 to 18 mm/h	every 8 hours
20 to 36 mm/h	every 4 hours
40 to 72 mm/h	every 2 hours
75 to 135 mm/h	every hour
150 to 180 mm/h	every 30 minutes
200 to 320 mm/h	every 20 minutes
360 to 1500 mm/h	every 10 minutes
more than 1500 mm/h	no printout

Dot Model

Chart Speed	Printing Interval of Periodic Printout			
	6 dot	12 dot	18 dot	24 dot
1 to 9 mm/h	no printout	no printout	no printout	no printout
10 to 19 mm/h	every 8 hrs.	every 12 hrs.	every 12 hrs.	every 24 hrs.
20 to 39 mm/h	every 4 hrs.	every 8 hrs.	every 8 hrs.	every 12 hrs.
40 to 50 mm/h	every 2 hrs.	every 4 hrs.	every 4 hrs.	every 8 hrs.
51 to 79 mm/h	every 2 hrs.	every 4 hrs.	no printout	no printout
80 to 100 mm/h	every hour	every 2 hrs.	no printout	no printout
101 to 1500 mm/h	no printout	no printout	no printout	no printout

If you selected MAN:

Specify the interval using the UP/DOWN-keys. You can choose from 10, 15, 20, 30 min and 1, 2, 3, 4, 6, 8, 12, 24 hrs. Then press the ENT-key. Note that when the printing takes more time than the specified interval, printouts may be skipped.

This setting has been completed, but has not been stored yet.

The display '*RCD SET*' will appear. You can now adjust other settings in the SET UP Mode, by using the ESC-key.

If you selected EXT:

The setting has been completed, but has not been stored yet. The display '*RCD SET*' will appear. You can now adjust other settings in the SET UP Mode, by using the ESC-key. Make sure to specify this also at the settings of the REMOTE option (see 9.8).

Before leaving the SET UP Mode, you have to store your new settings. Press the ESC-key to return to the 'SETUP=RCD' display and then select the 'SETUP=END' display.

Press the ENT-key. Select 'END=STORE' to keep your new settings or 'END=ABORT' and press the ENT-key. After a few seconds, the Operation Mode will appear.

9.6 How to Change the Temperature Unit (for USA)

For the TC or RTD type, the μ R1800 will automatically append the temperature unit ($^{\circ}$ C or $^{\circ}$ F). The initial value is ' $^{\circ}$ C', and common for all channels.

SETTING PROCEDURE:

Enter the SET UP Mode by turning 'ON' the power while pressing and holding the ENT-key until the SET UP display appears.

Select ' $^{\circ}$ C' or ' $^{\circ}$ F' using the UP/DOWN-keys.
Press the ENT-key. The display '*TEMP SET*' will appear.

This setting has been completed, but has not been stored yet. You can now adjust other settings in the SET UP Mode, by using the ESC-key.

Before leaving the SET UP Mode, you have to store your new settings. Press the ESC-key to return to the 'SETUP=TEMP' display and then select the 'SETUP=END' display.
Press the ENT-key. Select 'END=STORE' to keep your new settings or 'END=ABORT' and press the ENT-key. After a few seconds, the Operation Mode will appear.

CAUTION

When you change this setting, all settings in the SET Mode will return to their initial values. In the SET UP Mode, the RJC setting (9.2.3) and the input filter setting (9.2.4) will return to their initial values. Other settings in the SET UP Mode will not be affected. For a list, see 6.5

9.7 How to Initialize Settings

The settings which can be initialized concern the settings done in the SET Mode only. This initialization does not affect any settings in the SET UP Mode. For a list of initial settings of the SET Mode, see 6.5.

SETTING PROCEDURE:

Enter the SET UP Mode by turning 'ON' the power while pressing and holding the ENT-key until the SET UP display appears.

Use the UP/DOWN-keys to select the display 'SETUP=INIT'. Press the ENT-key.

Select 'YES' or 'NO' using the UP/DOWN-keys.
Press the ENT-key. The display '*INIT SET*' will appear.

This setting has been completed, but, in case you selected 'YES', settings have not been initialized yet. This will happen when you leave the SET UP Mode. You can now adjust other settings in the SET UP Mode, by using the ESC-key.

When leaving the SET UP Mode, and you want to initialize your settings, press the ESC-key. You will return to the 'SETUP=INIT' display and then select the 'SETUP=END' display.
Press the ENT-key. Select 'END=STORE' to initialize or 'END=ABORT' and press the ENT-key. After a few seconds, the Operation Mode will appear.

9.8 How to Change Initial Settings for the REMOTE Option

This paragraph describes the way to change initial settings for the REMOTE option. The settings concerning the REMOTE option are always accessible, and data entry will be ignored if your μ R1800 is not equipped with this option.

The /R1 option allows you to execute functions on the μ R1800 by a remote trigger (contact input).

The functions which can be executed by a remote trigger are:

- start/stop the recording (see also 9.8)
- change the chart speed to a preset second chart speed
- have messages printed out (up to 5 messages)
- get a manual printout
- get a periodic printout (see also 9.4.6)
- start/stop TLOG computation (only in combination with the MATH option)
- trigger the IC memory card (only in combination with the IC memory card option).

However, the /R1 terminal has only five terminals, which means that only five functions can be triggered. The printing out of one message takes up one terminal.

Initially the functions are assigned to the terminals as follows:

- 1: start/stop the recording (RECORD)
- 2: change the chart speed to a preset second chart speed (CHART_SPD)
- 3: get a manual printout (MANUAL_PR)
- 4: have message 1 printed out (MESSAGE1)
- 5: have message 2 printed out (MESSAGE2)

The purpose of this setting is to assign the to be triggered functions to the five terminals.

SETTING PROCEDURE:

Enter the SET UP Mode by turning 'ON' the power while pressing and holding the ENT-key until the SET UP display appears.

Use the UP/DOWN-keys to select the display 'SETUP=REM'. Press the ENT-key.

Select the terminal No. (CONT 1 to 5) (/R1 has five terminals.) Press the ENT-key.

Select the function which you want to assign to that terminal. You can choose from RECORD (start/stop recording) (see also 9.9), CHART_SPD (second chart speed), MESSAGE1, 2, 3, 4 or 5 (message No. 1, 2, 3, 4, 5), MANUAL_PR (manual printout), DGT_PR (periodic printout), TLOG or IC_TRIG.

Press the ENT-key. The display '*REM SET*' will appear.

This setting has been completed, but has not been stored yet. Press the ENT-key to set other terminals or press the ESC-key to adjust other settings in the SET UP Mode.

Before leaving the SET UP Mode, you have to store your new settings. Press the ESC-key to return to the 'SETUP=REM' display and then select the 'SETUP=END' display.

Press the ENT-key. Select 'END=STORE' to keep your new settings or 'END=ABORT' and press the ENT-key. After a few seconds, the Operation Mode will appear.

9.9 How to Select to Trigger the Recording to Start/Stop

The start/stop of the recording can be triggered by

- the RCD-key on the keyboard (INTernally triggered), or by
- remote control input (EXTernally triggered).

The initial value is 'INT'.

Note that if you specify the recording to start/stop in the REMOTE set up (as 'RECORD' in 9.7), and you fail to specify EXT here, the recording start/stop will not be controlled by remote control.

SETTING PROCEDURE:

Enter the SET UP Mode by turning 'ON' the power while pressing and holding the ENT-key until the SET UP display appears.

Use the UP/DOWN-keys to select the display 'SETUP=RCD'. Press the ENT-key.

The display 'RECORD=...' will appear. Select INT or EXT. Press the ENT-key.

This setting has been completed, but has not been stored yet. Before you can adjust other settings in the SET UP Mode, you have to finish the recording settings until the '*RCD SET*' display appears.

Before leaving the SET UP Mode, you have to store your new settings. Proceed with the recording settings until the '*RCD SET*' display appears. Press the ESC-key to return to the 'SETUP=RCD' display and then select the 'SETUP=END' display. Press the ENT-key. Select 'END=STORE' to keep your new settings or 'END=ABORT' and press the ENT-key. After a few seconds, the Operation Mode will appear.

9.10 How to Change Key-lock Settings

You can choose to use the key-lock or not.

'NOT' : all keys are operable, even when the key is removed from the key-hole.

'USE' : to select to 'USE' the key-lock affects the 3 modes in different ways.

Operation Mode:

- Even if you disable the keys (by removing the key from the key-hole), you can still change displays (as in 5.3.8).
- If you disable the keys (by removing the key from the key-hole), you cannot operate FUNC in the Operation Mode.
- The keys RCD/PRINT/ALARM ACK/FEED can be unlocked/locked individually.

SET Mode:

If you disable the keys (by removing the key from the key-hole), you cannot enter the SET Mode. If you try, the display will not change.

SET UP Mode:

Even if you disable the keys (by removing the key from the key-hole), you can always enter and operate the SET UP Mode.

The initial values are 'NOT' and 'LOCK' for all keys.

SETTING PROCEDURE:

Enter the SET UP Mode by turning 'ON' the power while pressing and holding the ENT-key until the SET UP display appears.

Use the UP/DOWN-keys to select the display 'SETUP=LOCK'. Press the ENT-key.

Select to USE the key-lock or NOT. Press the ENT-key. In the case you selected NOT, the setting is completed.

Select for the RCD, FEED, ALARM ACK and PRINT-key respectively to have them LOCKed or to have them FREE. Press the ENT-key after each selection.

The display '*LOCK SET*' will appear.

This setting has been completed, but has not been stored yet. You can now adjust other settings in the SET UP Mode, by using the ESC-key.

Before leaving the SET UP Mode, you have to store your new settings. Press the ESC-key to return to the 'SETUP=LOCK' display and then select the 'SETUP=END' display.

Press the ENT-key. Select 'END=STORE' to keep your new settings or 'END=ABORT' and press the ENT-key. After a few seconds, the Operation Mode will appear.

Chapter 10 GENERAL SPECIFICATIONS

MODELS

1, 2, 3 and 4 pen; 6 dot, 12 dot, 18dot and 24 dot printing model

TYPES

DCV : Direct Voltage input 20mV to 20V range.

TC : Thermocouple.

RTD : Resistance Temperature Detector.

DI : Digital Input (contact or DC Voltage, TTL level).

DCA : Direct Current Input (using external shunt resistor (10Ω, 100Ω, 250Ω)).

Measuring Range: selectable per channel

Input Type	Range	Measuring Range
DCV	20mV	-20.00 to 20.00mV
	60mV	-60.00 to 60.00mV
	200mV	-200.0 to 200.0mV
	2V	-2.000 to 2.000V
	6V	-6.000 to 6.000V
	20V	-20.00 to 20.00V

TC	Range	Measuring Range °C	Measuring Range °F
	R*1	0.0 to 1760.0°C	32 to 3200°F
S*1	0.0 to 1760.0°C	32 to 3200°F	
B*1	0.0 to 1820.0°C	32 to 3308°F	
K*1	-200.0 to 1370.0°C	-328 to 2498°F	
E*1	-200.0 to 800.0°C	-328.0 to 1472.0°F	
J*1	-200.0 to 1100.0°C	-328.0 to 2012.0°F	
T*1	-200.0 to 400.0°C	-328.0 to 752.0°F	
N*2	0.0 to 1300.0°C	32 to 2372°F	
W*3	0.0 to 2315.0°C	32 to 4199°F	
L*4	-200.0 to 900.0°C	-328.0 to 1652.0°F	
U*4	-200.0 to 400.0°C	-328.0 to 752.0°F	
PLT	0.0 to 1400.0°C	32 to 2552.0°F	
PR	0.0 to 1900.0°C	32 to 3452.0°F	

RTD	Range	Measuring Range °C	Measuring Range °F
	PT100*5	-200.0 to 600.0°C	-328.0 to 1112.0°F
	JPT100*5	-200.0 to 550.0°C	-328.0 to 1022.0°F
	JP50	-200.0 to 600.0°C	-328.0 to 1112.0°F
	CU1 to 6 (Cu10)	-200.0 to 300.0°C	-328.0 to 572.0°F
	CU25 (Cu25)	-200.0 to 300.0°C	-328.0 to 572.0°F

DI (Digital Input)	Range	Measuring Range
	Voltage input	less than 2.4V is OFF, more than 2.4V is ON(TTL)
	Contact input	contact ON/OFF

*1 R, S, B, K, E, J, T: ANSI, IEC 584, DIN IEC 584, JIS C 1602-1981

*2 N: Nicrosil-Nisil, IEC 584, DIN IEC 584

*3 W: W-5%Re / W-26%Re (Hoskins Mfg. Co.)

*4 L: Fe-CuNi, DIN 43710 U: Cu-CuNi, DIN 43710

*5 PT100: JIS C 1604-1989, JIS C 1606-1989, IEC 751, DIN IEC 751

JPT100: JIS C 1604-1981, JIS C 1606-1989

Calculation:

Differential computation: Between any two channels, however reference channel No. must be less than measuring channel No. Available for DCV, TC, and RTD range. Both channels must have same range.

Linear scaling: Available for DCV, TC and RTD range. (scaling) Scaling limits: –20000 to 20000 Data display & printout range: –19999 to 20000 Decimal point: user selectable (should be specified when entering scale value) Unit: user settable, up to 6 characters (alphanumerical & special characters).

Square root: Available for DCV range. Scaling limits: –20000 to 20000 Data display & printout range: –19999 to 20000 Decimal point: user selectable. Unit: user settable, up to 6 characters (alphanumerical & special characters).

Measuring and Recording Accuracy: (following specifications apply to operation of the recorder under standard operation conditions: temperature $23 \pm 2^\circ\text{C}$, humidity $55 \pm 10\%$ RH, power supply voltage according to the specifications, power supply frequency $50/60\text{Hz} \pm 1\%$, warm-up time at least 30 minutes, other ambient conditions should not adversely affect the recording operation).

Input	Range	Measuring (digital display)		Recording (analog)	
		Meas. Accuracy	Max. Resolution	Rec. Accuracy	Resolution
DCV	20mV	$\pm (0.2\% \text{ of rdg} + 3 \text{ digits})$	10 μV	measurement accuracy $\pm (0.3\% \text{ of recording span})$	pen: dead band: 0.2% of recording span dot: 0.1mm
	60mV	$\pm (0.2\% \text{ of rdg} + 2 \text{ digits})$	10 μV		
	200mV	$\pm (0.2\% \text{ of rdg} + 2 \text{ digits})$	100 μV		
	2V	$\pm (0.1\% \text{ of rdg} + 2 \text{ digits})$	1mV		
	6V	$\pm (0.3\% \text{ of rdg} + 2 \text{ digits})$	1mV		
	20V	$\pm (0.3\% \text{ of rdg} + 2 \text{ digits})$	10mV		

TC	R	$\pm (0.15\% \text{ of rdg} + 1^\circ\text{C})$	0.1 $^\circ\text{C}$	measurement accuracy $\pm (0.3\% \text{ of recording span})$	pen: dead band: 0.2% of recording span dot: 0.1mm
	S	but R, S: 0 to 100 $^\circ\text{C}$, $\pm 3.7^\circ\text{C}$			
	B	100 to 300 $^\circ\text{C}$, $\pm 1.5^\circ\text{C}$ B: 400 to 600 $^\circ\text{C}$, $\pm 2^\circ\text{C}$ accuracy less than 400 $^\circ\text{C}$ is not specified			
	K	$\pm (0.15\% \text{ of rdg} + 0.7^\circ\text{C})$ but –200 to 100 $^\circ\text{C}$ $\pm (0.15\% \text{ of rdg} + 1^\circ\text{C})$	0.1 $^\circ\text{C}$		
	E	$\pm (0.15\% \text{ of rdg} + 0.5^\circ\text{C})$			
	J	$\pm (0.15\% \text{ of rdg} + 0.5^\circ\text{C})$			
	T	but J: –200 to –100 $^\circ\text{C}$ $\pm (0.15\% \text{ of rdg} + 0.7^\circ\text{C})$			
	N	$\pm (0.15\% \text{ of rdg} + 0.7^\circ\text{C})$	0.1 $^\circ\text{C}$		
	W	$\pm (0.15\% \text{ of rdg} + 1^\circ\text{C})$			
	L	$\pm (0.15\% \text{ of rdg} + 0.5^\circ\text{C})$	0.1 $^\circ\text{C}$		
U	but L: –200 to –100 $^\circ\text{C}$ $\pm (0.15\% \text{ of rdg} + 0.7^\circ\text{C})$				
PR40-20	not specified	0.1 $^\circ\text{C}$			
0 to 450	$\pm (0.9\% \text{ of rdg} + 3.2^\circ\text{C})$				
450 to 750	$\pm (0.9\% \text{ of rdg} + 1.3^\circ\text{C})$				
750 to 1100	$\pm (0.9\% \text{ of rdg} + 0.4^\circ\text{C})$				
1100 to 1900					
PRATINEL	$\pm (0.25\% \text{ of rdg} + 2.3^\circ\text{C})$	0.1 $^\circ\text{C}$			

RTD meas. current = 1mA	PT100	$\pm (0.15\% \text{ of rdg} + 0.3^\circ\text{C})$	0.1°C	measurement accuracy $\pm (0.3\% \text{ of recording span})$	pen: dead band: 0.2% of recording span dot: 0.1 mm
	JPT100				
	JPt50	$\pm (0.3\% \text{ of rdg} + 0.5^\circ\text{C})$			
	Cu10				
	(Cu1 to 6)	$\pm (0.4\% \text{ of rdg} + 1.0^\circ\text{C})$			
	Cu25	$\pm (0.3\% \text{ of rdg} + 0.8^\circ\text{C})$			

Note : Recording span is 180mm.

Accuracy in Case of Scaling:

Accuracy during scaling (digits) =
measuring accuracy (digits) \times multiplier + 2 digits (rounded up)
where the multiplier = scaling span digits / measuring span digits

Example: DCV 6V range

measuring span: 1.000 to 5.000V
scaling span: 0.000 to 2.000
measuring accuracy = $\pm (0.3\% \times 5V + 2 \text{ digits})$
 $\pm (0.015V [15 \text{ digits}] + 2)$
 $\pm (17 \text{ digits})$
multiplier = $2000 \text{ digits } (0.000 \text{ to } 2.000) / 4000 \text{ digits } (1.000 \text{ to } 5.000V) = 0.5$

Accuracy during scaling = 17 digits \times 0.5 + 2 = 11 digits (rounded up)

Maximum Allowable Input Voltage:

Less than 2VDC ranges and TC ranges: $\pm 10VDC$ (cont.)
6V to 20VDC: $\pm 30VDC$ (cont.)

Reference Junction Compensation:

INT/EXT selectable (per channel)

Reference Junction Compensation Accuracy (above 0°C):

Type R, S, B, W: $\pm 1^\circ\text{C}$
Type K, J, E, T, N, L, U: $\pm 0.5^\circ\text{C}$

Measurement Interval:

A/D Frequency	100ms	50/60Hz
pen model	—	125ms
6 dot model	2.5s	2.5s
12 dot model	5s	2.5s
18 dot model	10s	2.5s
24 dot model	10s	2.5s

A/D Integration Time:

AUTO: 20ms (50Hz) or 16.7ms (60Hz), selected automatically
50Hz: 20ms
60Hz: 16.7ms
100ms (dot model)

TC Burnout:

ON/OFF selectable (per channel).
Burnout upscale/downscale selectable (common for all channels).
Normal: less than 2k Ω , burnout: more than 10M Ω .
Measuring current: approx. 100nA.

Filter:

pen : Signal damping (ON/OFF selectable per channel, in case of ON: time constant from 2, 5, 10 sec selectable per channel).
dot : Moving average (ON/OFF selectable per channel, in case of ON: averaging times from 2 to 16).

RECORDING and PRINTING

Recording Method:

pen : Disposable felt pens, plotter pen
dot : 6 Color wire dot

Pen Offset Compensation: ON/OFF selectable, for pen model only

Effective Recording Width: 180mm

Chart:

plain-paper Z-fold chart (20m)

Step Response Time:

Less than 1.5sec (acc. to IEC TC85 method).

- Recording Period:** pen : Continuous for each channel.
dot : max. 6 ch./10 sec, 12ch./15 sec, 18ch./20 sec, 24ch./30 sec, AUTO/FIX selectable
AUTO : Analog recording interval is depending on the chart speed.
FIX : Analog recording interval is set to shortest period.
- Chart Speed:** pen : 5 to 12000 mm/h (82 increments)
dot : 1 to 1500 mm/h (1mm step)
- Chart Speed Change:** speed 1, speed 2 change by remote control signals (option).
- Chart Feed Accuracy:** within $\pm 0.1\%$ (for recordings longer than 1000mm), related to the grid of the chart paper
- Recording Colors:** pen : pen1=red, pen2=green, pen3=blue, pen4=violet plotter pen=purple
dot : ch1,7,13,19= purple, ch2,8,14,20= red, ch3,9,15,21= green, ch4,10,16,22= blue,
ch5,11,17,23= brown, ch6,12,18,24= black (color can be assigned to any channel).
- Recording Format:**
- 1 Analog Recording:
 - Zone recording: span more than 5mm, 1mm step
 - Partial expanded recording: Boundary position: 1 to 99%
(dot model only) Boundary value: within recording span
 - 2 Digital Printout:
 - Channel or tag printout: Channel number or tag will be printed during analog recording. Every 25mm this print will occur. Selectable, common for all channels.
 - Alarm printout: At the right side of the chart, channel No. or tag, type of alarm, ON/OFF time (h/m) will be printed. It is selectable to get ON/OFF-time of alarms printed, or ON-time only, or no alarms (common for all channels).
 - Periodic printout: At the left side of the chart, date (m/d), time (h/m), chart speed, and measured data of every channel will be printed. Printing interval is INT/EXT selectable.
INT: Using internal timer. Depending on chart speed or on interval which is selectable (up to 24 hours).
EXT: Using remote control option.
 - Channel No. or TAG printout: Selectable, common for all channels.
 - Printout of measured data: ON/OFF selectable for each channel.
 - Scale printout: For 40mm zones and bigger, at 0% and 100% values will be printed. (When using partial expanded recording, boundary value will also be printed.)
ON/OFF selectable, common for all channels.
Printout of recording colors
 - Message printout: Using keyboard or remote control option. Up to five messages.
Contents: time (h/m) and message (up to 16 characters).
 - Record start time: Time (h/m) will be printed when recording starts, ON/OFF selectable.
 - Chart speed printout: Time (h/m) when chart speed is changed will be printed.
ON/OFF selectable.
 - List printout: Listings of range and alarm settings, etc. will be printed.
 - SET UP list printout: Listings of settings in SET UP Mode will be printed.
 - Manual printout: Using keyboard or remote control option.

Relation between Chart Speed and Printout:

Pen Model

Recording Chart Speed	Periodic Printout	Alarm Printout/ Message Printout/ Recording Start Time/ Time of Chart Speed Change/ Channel or Tag Printout
5 to 9mm	no printout	printout
10 to 1500mm	printout	
1600 to 12000mm	no printout	

Dot Model

Chart Speed	Periodic Printout		Alarm Printout/ Time of Chart Speed Change/ Recording Start Time/ Message Printout/ Channel or Tag Printout	
	6, 12 dot	18, 24 dot	6, 12 dot	18, 24 dot
1 to 9 mm/h	no printout	no printout	printout	printout
10 to 50 mm/h	printout	printout	printout	printout
51 to 100 mm/h	printout	no printout	no printout	no printout
101 to 1500 mm/h	no printout	no printout	no printout	no printout

Relation between Chart Speed and Intervals of Periodic Printout:

Pen Model

Chart Speed	Printing Interval of Periodic Printout
5 to 9 mm/h	no printout
10 to 18 mm/h	every 8 hours
20 to 36 mm/h	every 4 hours
40 to 72 mm/h	every 2 hours
75 to 135 mm/h	every hour
150 to 180 mm/h	every 30 minutes
200 to 320 mm/h	every 20 minutes
360 to 1500 mm/h	every 10 minutes
more than 1500 mm/h	no printout

Dot Model

Chart Speed	Printing Interval of Periodic Printout			
	6 dot	12 dot	18 dot	24 dot
1 to 9 mm/h	no printout	no printout	no printout	no printout
10 to 19 mm/h	every 8 hrs.	every 12 hrs.	every 12 hrs.	every 24 hrs.
20 to 39 mm/h	every 4 hrs.	every 8 hrs.	every 8 hrs.	every 12 hrs.
40 to 50 mm/h	every 2 hrs.	every 4 hrs.	every 4 hrs.	every 8 hrs.
51 to 79 mm/h	every 2 hrs.	every 4 hrs.	no printout	no printout
80 to 100 mm/h	every hour	every 2 hrs.	no printout	no printout
101 to 1500 mm/h	no printout	no printout	no printout	no printout

DISPLAY

Display Method:

VFD (5 × 7 dot matrix, 20 characters).

Digital Display:

AUTO Channel No. or tag, type of alarm, measured values, unit (front 3 digits), for each channel alternately

MAN Channel No. or tag, type of alarm, measured values, unit (front 3 digits), for one specific channel

CLOCK Year / month / date and hour / min / sec will be displayed

VIEW Status for IC Memory Card and TLOG function will be displayed

Bargraph Display:

Measured data Left-centered (%) bargraph and center-zero bargraph (selectable for each channel).

Alarm Setting level of alarm, in case of alarm: flashing display.

Other Displays:

RCD: recording in progress

POC: Pen Offset Compensation (pen model only)

SET: SET Mode

AUTO: Auto display is used

MAN: Manual display is used

CLK: Clock display is used

ALM: shared alarm (not corresponding to any channel)

CHT: Chart end indicator (optional)

BAT: low battery

ALARM

Number of Levels:

Up to four levels for every channel (High, Low, Delta high, Delta low, High rate-of-change, Low rate-of-change selectable)

Interval time of rate-of-change alarm is the measuring interval multiplied by 1 to 15 (selectable, and common for both rate-of-change alarms).

Display:

Set value: Is indicated as a segment on the bargraph.

In case of alarm: This segment will start flashing on the bargraph and the digital display will show the type of alarm. The alarm indicator in different display will show alarm.

Hysteresis:

Approx. 0.5% of recording span (only High, Low) and 0%, selectable (common for all channels and all levels).

Alarm Indication When ALARM ACK-key is Pressed:

Non-Hold type: Alarm display is not affected when the ALARM ACK-key is pressed.
Hold type: When alarm occurs, alarm indicator will start flashing. After pressing the ALARM ACK-key, the indicator will show the status of the alarm.

Hold type:

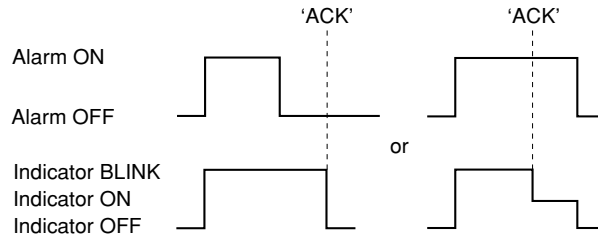

Non-Hold type:

No action will occur when ACK-key is pressed.
ALM indicator depends on alarm status.

PERFORMANCE and CHARACTERISTICS

Input Resistance: more than 10M Ω (TC, 20mV, 60mV, 200mV, 2V range)
approx. 1M Ω (6, 20V range).

Input Source Resistance: DCV, TC input: less than 2k Ω
RTD input: less than 10 Ω /wire. (Resistance is balanced between 3 wires)

Input Bias Current: less than 10nA (however, when burnout is specified for TC: 100nA).

Maximum Common Mode Voltage:
250VAC rms (50/60Hz)

Maximum Differential Noise Between Channels (50, 60Hz):
250VAC rms

Interference Between Channels:
120dB (R_g = 500 Ω , the deviation in case 30V is applied to another channel)

Common Mode Rejection Ratio:
120dB (50/60Hz \pm 0.1%, 500 Ω imbalance between \ominus terminal and ground)

Normal Mode Rejection Ratio:
40dB (50/60Hz \pm 0.1%)

Insulation Resistance: each terminal to ground terminal: more than 20M Ω (measured at 500VDC).

Dielectric Strength:

power supply to ground terminal:	1500VAC(50/60Hz), 1 min
contact output terminal to ground:	1500VAC(50/60Hz), 1 min
measuring input terminal to ground:	1000VAC(50/60Hz), 1 min
between measuring input terminals:	1000VAC(50/60Hz), 1 min
(except for RTD)	
REMOTE terminal to ground:	500VAC, 1mm

EMC Conformity Standard(for standard model except for /P1 model)

EMI EN55011: Class A
EMS EN50082-2

IEC1000-4-2: Electrostatic Discharge	8 kV(Air) 4 kV(Contact)	Performance Criteria B
IEC1000-4-3: Radiated fields	80MHz-1000MHz 10V/m	Performance Criteria A (Pen Model: $\pm 5\%$ of Range) (Dot Model: $\pm 20\%$ of Range)
IEC1000-4-4: Fast Transient	AC power line 2kV The others 1 kV	Performance Criteria B
IEC1000-4-6: Conducted Disturbance	0.15MHz - 80MHz, 10V	Performance Criteria A ($\pm 5\%$ of Range)
IEC1000-4-8: Magnetic Field	50Hz, 30A/m	Performance Criteria A

CONSTRUCTION

Mounting: Flush Panel Mounting (vertical), mounting next to each other (horizontal).
Mounting may be inclined up to 30°, rear below front (with horizontal base).

Allowable Panel Thickness: 2 to 26mm.

Material: Case: drawn steel, front door: aluminium die casting.

Finish: Case and door-frame: lampblack (Mansell 0.8Y 2.5 / 0.4 or equivalent).

Door: Splash-proof (in accordance with DIN 40050-IP54).

Dimensions: 288(W) × 288(H) × 220(D) mm

Weight:

1 pen model	8.9kg	6 dot printing model	9.1kg
2 pen model	9.0kg	12 dot printing model	9.4kg
3 pen model	9.2kg	18 dot printing model	9.5kg
4 pen model	9.4kg	24 dot printing model	9.6kg

POWER SUPPLY

Rated Power Voltage: for others than /P1 model; 100 to 240VAC, automatically selected depending on the power supply voltage.
45 to 65Hz, automatically adjusted.
/P1 model; 24VDC

Usable Power Voltage Ranges: for others than /P1 model; 90 to 132, 180 to 250VAC
/P1 model; 21.6 to 26.4VDC

Rated Power Frequency: 50/60Hz, no need to change switches (for others than /P1 model)

Power Consumption: (for others than /P1 model)

	100VAC Power Source	240VAC Power Source	max.
4 pen	30VA*	40VA*	70VA
dot	23VA*	32VA*	70VA

*: in balance

/P1 model; 23VA (4 pen), max 50VA

NORMAL OPERATING CONDITIONS

Power Voltage: for others than /P1 model; 90 to 132, 180 to 250VAC
/P1 model; 21.6 to 26.4VDC

Power Frequency: 50Hz $\pm 2\%$, 60Hz $\pm 2\%$ (for others than /P1 model)

Ambient Temperature: 0 to 50°C

Ambient Humidity: 20 to 80% RH (at 5 to 40°C)

Vibration: 10 to 60Hz, less than 0.02G

Shock: not permissible

Magnetic Field:	less than 400AT/m (DC and 50, 60Hz)
Noise:	Normal Mode (50, 60Hz)
	DCV Peak value including signal must be less than 1.2 times the measuring range.
	TC Peak value including signal must be less than 1.2 times the measuring mV.
	RTD less than 50mV.
	Common Mode (50, 60Hz) less than 250VAC rms for the whole range.

Maximum Differential Noise Between Channels (50, 60Hz):
less than 250VAC rms

Operating Position: frontwards: 0° backwards: within 30°

Warm-up Time: at least 30 minutes after the power has been turned ON.

EFFECT OF OPERATION CONDITIONS

Effect of Ambient Temperature:

Effect of ambient temperature variation of 10°C,
 Digital display: within \pm (0.1% of rdg + 1 digit)
 Recording: within Digital display \pm 0.2% of recording span (excluding RJC-error)

Effect of Power Supply: Effect of variation in rated power supply voltage: (50 or 60Hz is reference, rated power supply voltage is according to specifications)

Digital display: within \pm 1 digit
 Recording: within \pm 0.1% of recording span
 Effect of rated power frequency variation of \pm 2Hz (100VAC is reference):
 Digital display: within \pm (0.1% of rdg + 1 digit)
 Recording: same as digital display

Effect of Magnetic Field: Effect of AC (50/60Hz) or DC 400AT/m field:

Digital display: within \pm (0.1% of rdg + 10 digit)
 Recording: within \pm 0.5% of recording span

Effect of Input Source Resistance:

Effect of Input Source Resistance variation of +1k Ω :
 DCV range:
 Ranges less than 2V: within \pm 10 μ V
 Ranges more than 6V: within $-$ 0.1% of rdg
 TC range: within \pm 10 μ V (However \pm 100 μ V when TC burnout protection is set)
 RTD range:
 Effect of 10 Ω per wire (resistances of three wires must be equal):
 Digital display: within \pm (0.1% of rdg + 1 digit)
 Recording: within Digital display \pm 0.1% of recording span
 Effect of difference of three wires: Digital display: 0.1°C per 40m Ω (approx.)

Effect of Operating Position:

Digital display: within \pm (0.1% of rdg + 1 digit) (within 30° backwards)
 Recording: within Digital display \pm 0.1% of recording span (within 30° backwards)

Vibration: Effect when sine-wave motion of frequency 10 to 60Hz and acceleration of 0.02G is applied to the instrument in the direction of three axes each for two hours:

Digital display: within \pm (0.1% of rdg + 1 digit)
 Recording: within Digital display \pm 0.1% of recording span

Effect of radio-frequency Common Mode (Except for /P1 model):

Effect of 0.15M-80MHz 10V
 Digital display: within \pm (5% of range \pm 1 digit)

Recording: within $\pm(5\%$ of range)

TRANSPORT and STORAGE CONDITIONS

No malfunction will occur under these conditions, however when returning to normal operation conditions, calibration might be necessary.

Temperature: -25 to 60°C
Humidity: 5 to 95% RH (no condensation)
Vibration: 10 to 60Hz, 0.5G
Shock: less than 40G (inside packings)

OTHER SPECIFICATIONS

Clock: with Calendar function
Accuracy: ± 100 PPM, however not including error due to turning ON/OFF power
Panel Key-lock: By actual key: panel keys which should not be locked can be assigned
Internal Illumination: Using internal reflection of VFD display
Memory Backup: Lithium battery to preserve setting parameters. Life is approx. ten years (at room temperature, and for standard model) and is installed inside the recorder. If the battery runs out, this will be shown on the front panel indicator.
Machine noise: Machine Noise Information Ordinance 3. GSGV, January 18, 1991: The maximum sound pressure level is equal or less than 60dB (A) according to ISO7779.

SAFETY STANDARDS

Based on: Certified CSA 22.2 No.1010.1
Complies with EN61010-1

Chapter 11 MAINTENANCE

11.1 Periodic Maintenance

Check the recorder operation periodically to keep the recorder in good operation condition.

Especially, check the following items and replace consumable parts such as chart, disposable felt-tip pens, fuse and batteries, etc. as needed.

- Are display and recording functioning properly?
If not, see chapter 12 'Troubleshooting'.
- Are there blurred or broken sections of recording or printout characters?
If so, replace the relevant felt-tip pen or plotter pen. For replacement, see 5.2.2.
- Is the chart paper feeding properly?
If not, see chapter 12 'Troubleshooting'.
- Is there enough chart paper left?
The remaining chart paper length is printed on the right side margin of the chart at intervals of 15cm. See figure 11.1.
For replacement of the chart paper, see 5.2.1.

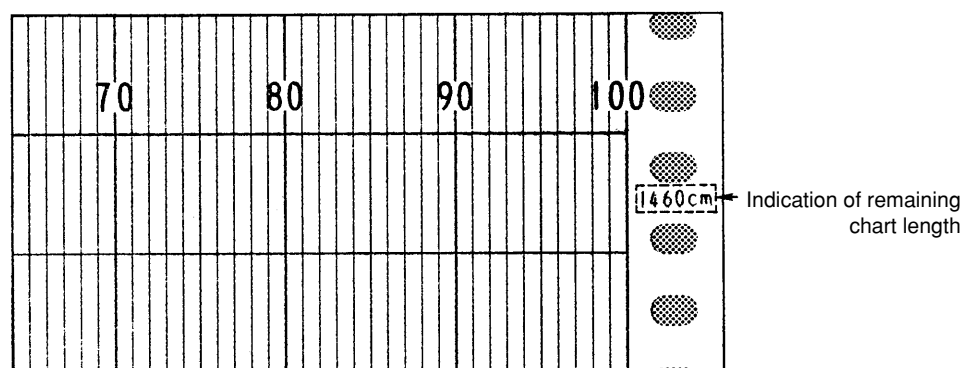

Figure 11.1 Indication of Remaining Chart Length

- Is the indicator 'BAT' illuminated or flashing?
If the indicator is illuminated, the lithium battery needs to be replaced. For replacement, contact your nearest Sales & Service Office. Addresses may be found on the back cover of this manual.
If the indicator is flashing, the IC Memory Card battery needs to be replaced.
For replacement, see the IC Memory Card Instruction Manual IM 4H3B1-30E.

WARNING

To avoid injury, never replace the lithium battery yourself.

11.2 Fuse Replacement

Replace the fuse at least once every two years for preventive maintenance. To replace the fuse, turn OFF the main power supply.

- 1 Remove the chart compartment.
Do this as follows:
While gently pressing the chart paper compartment lock tab, located in the middle at the lower front, in the direction of the arrow, swing and lift the compartment from the unit.
- 2 The fuse is now visible in the right lower front of the plate. See also figure 11.2. Turn the knob of the fuse holder counterclockwise, and the holder will slide out with the fuse.
- 3 Make sure that the new fuse rating is correct and mount the new fuse by turning the knob clockwise.

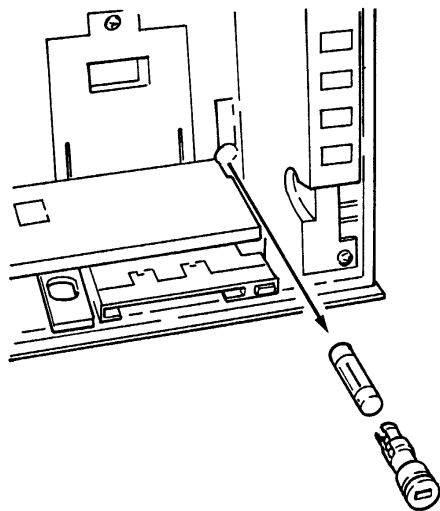

Figure 11.2 Fuse Replacement

WARNING

Before replacing the fuse, make sure to turn OFF the power supply and disconnect the power source. Use only specified fuses which should be obtained from your nearest Sales & Service Office. The use of other fuses might cause fire.

11.3 Pen Adjustment (Pen Model)

It is recommended to adjust the position of the pens once a year.

To adjust the pens, proceed as follows:

- Allow a warm-up time for the recorder of at least 30 minutes. Check that the ambient temperature and humidity are within Normal Operating Conditions (see chapter 10 'General Specifications').
- Enter the SET UP Mode by turning 'ON' the power while pressing and holding the ENT-key until the SET UP display appears.
- Press the ENT-key until the display 'SETUP=P_ADJ' appears. Press the ENT-key.
- You can now select to adjust the ZERO position of the pens (left side of the chart) or the FULL position of the pens (right side of the chart). It is recommended to adjust the ZERO position before the FULL position. After selection press the ENT-key.
- Select the channel number (= pen number) which you want to adjust. Then press the ENT-key.
- Change the numeric value and the pen will move to its new position after having pressed the ENT-key. Continue this procedure until the pen is in its correct position. Changing the value 1 digit will result in a pen movement of approximately 0.01mm. A + change will result in movement to the right. The correct position can be checked by use of the grid on the chart.
- This adjustment has been completed, but before leaving the SET UP Mode, you have to store these settings. Press the ESC-key to return to the 'SETUP=P_ADJ' display and then select the 'SETUP=END' display. Press the ENT-key. Select 'END=STORE' to keep your new settings or 'END=ABORT' and press the ENT-key. After a few seconds, the Operation Mode will appear.

11.4 Printer Carriage Adjustment (Dot Model)

It is recommended to adjust the position of the carriage once a year.

To adjust the carriage, proceed as follows:

- Allow a warm-up time for the recorder of at least 30 minutes. Check that the ambient temperature and humidity are within Normal Operating Conditions (see chapter 10 'General Specifications').
- Enter the SET UP Mode by turning 'ON' the power while pressing and holding the ENT-key until the SET UP display appears.
- Press the ENT-key until the display 'SETUP=P_ADJ' appears. Press the ENT-key.
- You can now select to adjust the ZERO position of the carriage (left side of the chart), HYS position of the carriage (middle of the chart) or the FULL position of the carriage (right side of the chart). It is recommended to adjust the HYS position first, and ZERO position before the FULL position. Select HYS and press the ENT-key.

The carriage should print a straight line, but might print as follows:

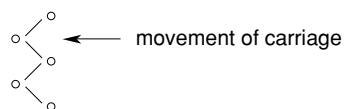

Figure a

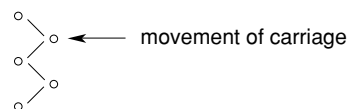

Figure b

If the line looks like the one shown in figure a, adjust the value on the display to a bigger value. Then press the ENT-key.

If the line looks like the one shown in figure b, adjust the value on the display to a smaller value. Then press the ENT-key.

Continue this procedure until the carriage prints a straight line. Changing the value 1 digit will result in a carriage movement of approximately 0.1mm.

- Then select ZERO. The carriage will print a line on the left side of the chart. This line should be the '0' position. If the line is printed before the '0' position (which can be seen from the grid on the chart), adjust this by entering a bigger value. After adjusting, press the ENT-key.
- Then select FULL. The carriage will print a line on the right side of the chart. This line should be the '100' position. If the line is printed before the '100' position (which can be seen from the grid on the chart), adjust this by entering a bigger value. After adjusting, press the ENT-key.
- This adjustment has been completed, but before leaving the SET UP Mode, you have to store these settings. Press the ESC-key to return to the 'SETUP=P_ADJ' display and then select the 'SETUP=END' display. Press the ENT-key. Select 'END=STORE' to keep your new settings or 'END=ABORT' and press the ENT-key. After a few seconds, the Operation Mode will appear.

11.5 Calibration

It is recommended to perform a calibration once a year to assure the measuring accuracy.

Required instruments:

DC Voltage Standard: YOKOGAWA Model 2552 or equivalent.

Decade Resistance Box: YOKOGAWA Model 2793-01 or equivalent.

Calibration procedure:

- 1 Connect the calibration instrument to the input terminals of the recorder as shown in figures 11.3, 4 , 5 or 6 and allow the recorder to warm up for at least 30 minutes. Allow the instrument to warm up according to its specifications.
- 2 Check that the ambient temperature and humidity are within Normal Operating Conditions (see chapter 10 'General Specifications').
- 3 Apply an input corresponding to 0, 50 and 100 percentage of the entered setting range, and calculate errors from the readings on the display.
- 4 If the error is at any point outside the accuracy limits (for accuracies, see chapter 10 'General Specifications'), contact your nearest Sales & Service Office. Addresses may be found on the back cover of this manual.

NOTE For a TC input, it is necessary to measure the temperature of the input terminals, and add a voltage corresponding to the reference temperature.

DC Voltage Measurement

The figure below shows the pen model, but connection should be done in the same way for the dot model.

Power Supply terminal
(for others than /P1 model)

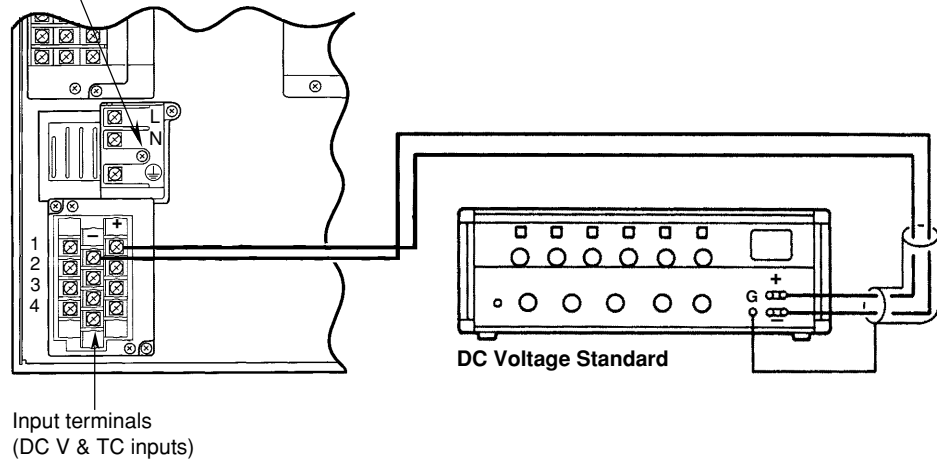
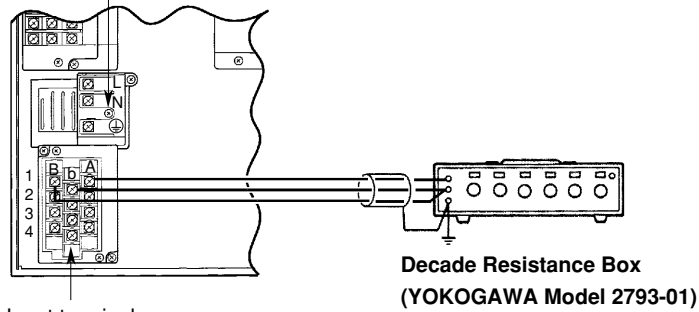

Figure 11.3 DC Voltage Measurement

Temperature Measurement Using RTD for the Pen Model

Power supply terminal
(for others than /P1 model)



Input terminals
(DC V & TC inputs)

Figure 11.4 Temperature Measurement Using RTD (Pen Model)

Temperature Measurement Using RTD for the Dot Model

Power supply terminal
(for others than /P1 model)

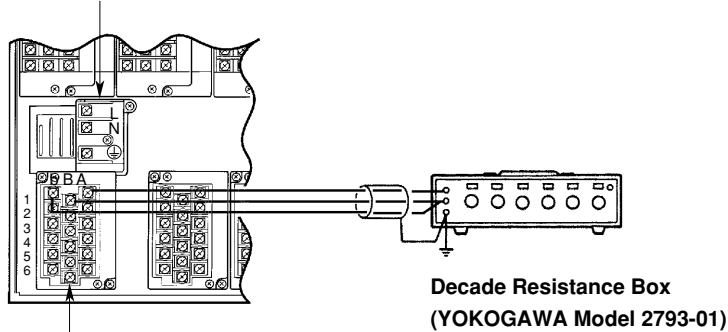

Input terminals
(RTD inputs)

Figure 11.5 Temperature Measurement Using RTD (Dot Model)

Temperature Measurement Using TC

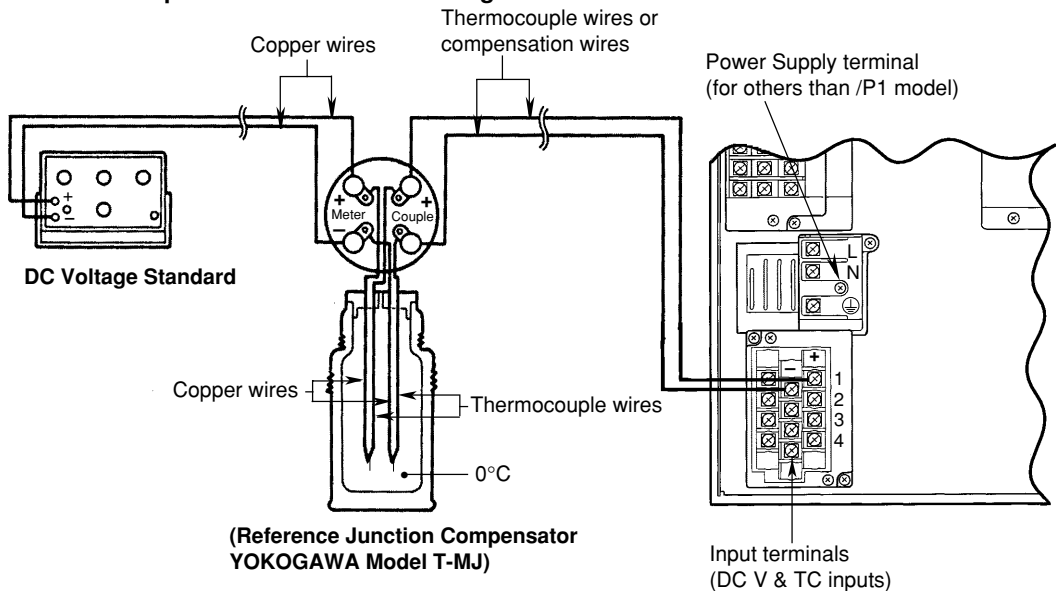

Reference Junction Compensation for Thermocouple Input

As the temperature at the measurement terminal of the recorder is generally equal to the room temperature, a voltage is applied to the inside circuit to obtain the equivalent of 0°C. Therefore when the measurement terminals are shorted (equivalent to 0°C at detector tip in the reference table) the room temperature (equals the temperature at the measurement terminal) is displayed. As a result, the recorder is measuring the temperature of the input terminal and compensates this value. When calibrating the recorder, the input voltage without subtracting the compensation voltage should be applied (For example, use the YOKOGAWA Model T-MJ reference Junction compensator shown above).

Figure 11.6 Temperature Measurement Using TC

11.6 Cleaning the Plotter Carriage Shaft (Pen Model)

When using the recorder under normal operating conditions, periodically inspect the plotter carriage shaft for dirt. It is recommended that the plotter carriage shaft be cleaned at least once a year.

To clean, proceed as follows:

- 1 Remove the chart cassette.
- 2 Two shafts (upside and downside of the plotter carriage) are visible (see figure 11.7). Wipe off dirt with a soft cloth without fibers. If the dirt is persistent, you may use ethyl alcohol.

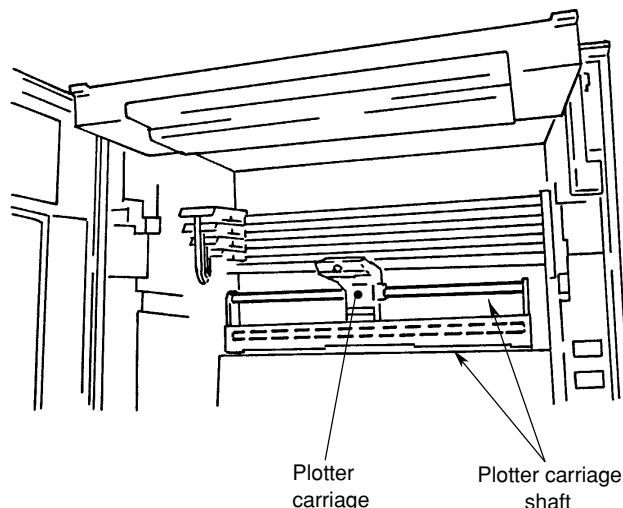

Figure 11.7 Plotter Carriage Shafts

CAUTION

Exercise care not to damage the flexible wiring strip connected to the printer carriage. Do not apply any oil to the shafts.

11.7 Lubrication (Dot Model)

When using the recorder under normal operating conditions, periodically inspect the carriage shaft for adequate lubrication. It is recommended that the carriage shaft be lubricated at least every year.

To lubricate, proceed as follows (see figure 11.8):

- 1 Wipe off dirt and accumulated oil from the carriage shaft with a soft cloth (without fibers).
- 2 Use only the specified lubricating oil (spare B9901AZ).
- 3 Put a small amount of lubricating oil on the shaft. Wipe off any excess oil with a soft cloth (without fibers).

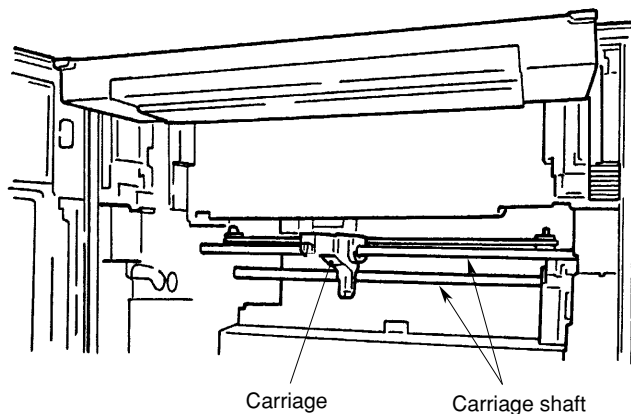

Figure 11.8 Lubrication

Chapter 12 TROUBLESHOOTING

This chapter describes the cause and countermeasures to be taken in case errors or failures occur.

- 12.1 Error message table
- 12.2 Troubleshooting flow chart

12.1 Error Message Table

Error Message (on display)	Error Description	Countermeasure
ERROR 001	Main recorder related errors other than those below	contact your nearest Service center
ERROR 002	Value entered exceeds allowable setting range	enter correct value
ERROR 003	Time setting error	enter correct time
ERROR 004	Attempted to enter a channel which cannot be selected	enter correct channel
ERROR 005	Illegal parameter concerning IC Memory Card & Communication	see special option manuals IM 4H3B1-10E/ IM 4H3B1-30E
ERROR 006	Attempted to select illegal option	
ERROR 011	Attempted to perform a list, setup, manual or message printout when out of chart	insert chart, see 5.2.1
ERROR 012	Attempted to change pens while recording	stop recording, see 5.2.2
ERROR 040	Reference channel number is larger than the DELTA channel number	enter correct ref. channel, see 7.1.5
ERROR 041	DELTA reference channel set up for SKIP	change range setting, see 7.1
ERROR 042	DELTA reference channel set up for DI	change range setting, see 7.1
ERROR 043	DELTA reference channel set up for SCALE or SQRT	change range setting, see 7.1
ERROR 045	Left span value is same as right span value	change span value, see 7.1
ERROR 046	Left scale value is same as right scale value	change scale value, see 7.1.6
ERROR 060	Attempted to set alarm on SKIP channel	change range setting, see 7.1
ERROR 061	Attempted to set alarm on DI channel	change range setting, see 7.1
ERROR 083	Channel set to PARTIAL has a range set to SKIP	change range setting, see 7.1
ERROR 084	Channel set to PARTIAL has a range set to DI	change range setting, see 7.1
ERROR 086	Left zone value is same as right zone value	change zone value, see 8.1.1
ERROR 087	Left zone value is bigger than right zone value	change zone value, see 8.1.1
ERROR 088	Band between left and right zone values is less than 5mm	change zone value, see 8.1.1
ERROR 160	Communication related error	see special option manual IM 4H3B1-10E
ROM ERROR	System ROM failure	contact your nearest Service center
RAM ERROR	Main memory failure	contact your nearest Service center
NV ERROR 1	Main NV RAM failure	contact your nearest Service center
NV ERROR 2	All A/D NV RAM failure	contact your nearest Service center
AD NV ERR <input type="checkbox"/>	ch AD NV RAM failure (<input type="checkbox"/> ch will be skipped)	contact your nearest Service center
AD ADJ ERR <input type="checkbox"/>	ch A/D calibration data error (<input type="checkbox"/> ch will be skipped)	contact your nearest Service center
PLOTTER ERR	Plotter board failure	contact your nearest Service center
COMM ERR	Communication board error	contact your nearest Service center
COMM REMOVE	The communication function is now out of use	contact your nearest Service center

Self Diagnosis Message (printout)	Description
STORE SET UP SETTINGS AGAIN	SET UP settings must be reconfirmed to maintain reliability. Proceed as follows: Enter the SET UP Mode. Select the 'SETUP=END' display. Press the ENT-key and STORE. (see also chapter 9.)

12.2 Troubleshooting Flow Chart

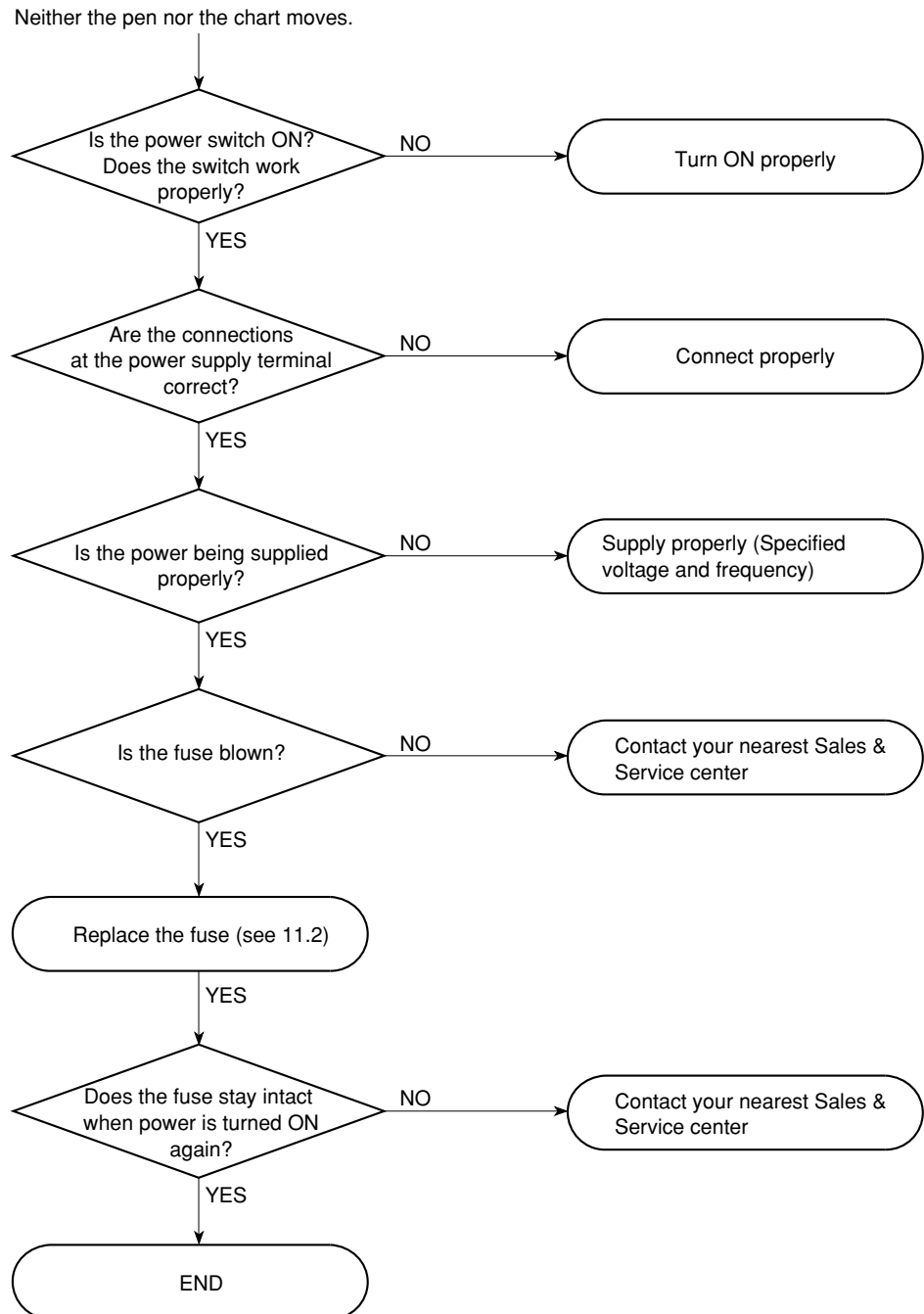

The input value and measured value are very different.
 (e.g. pens are staying at 0% or 100% of the chart, big fluctuations.)

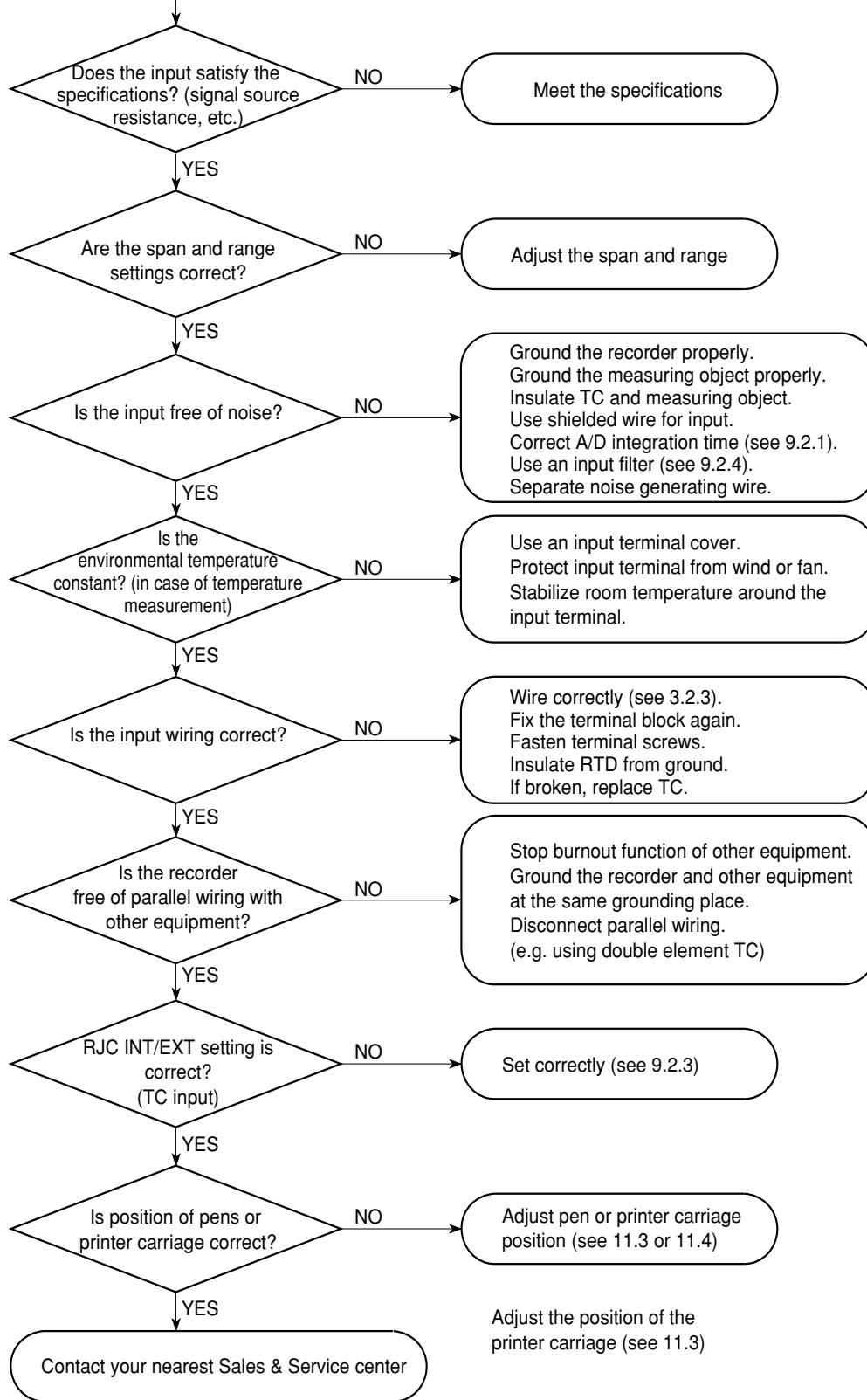

Display and functions do not work properly.

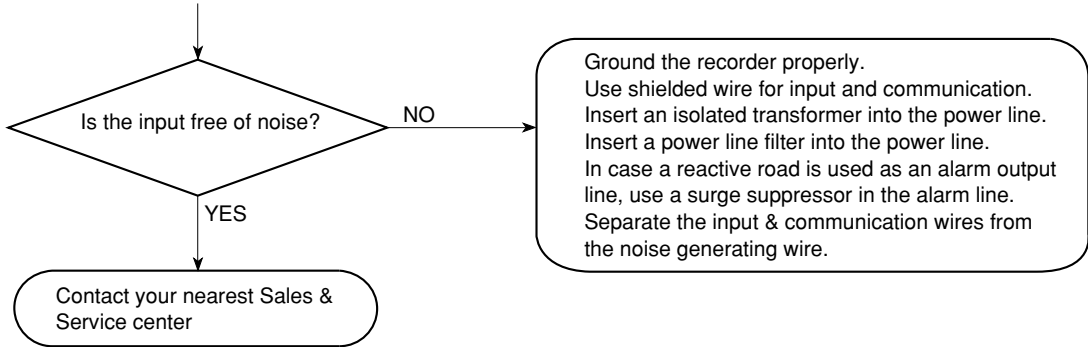

Panel key does not work properly.

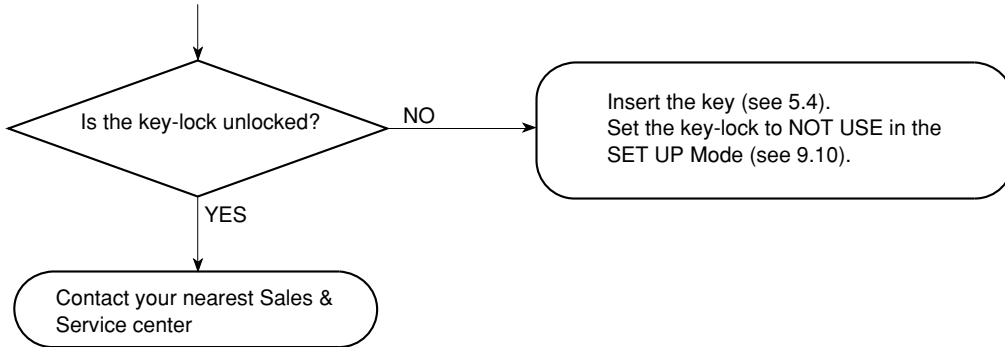

TERMINOLOGY

allowable input voltage	The maximum input voltage that can be applied to the input terminals
burnout	Failure of a device due to excessive heat
common-mode rejection ratio	The ability of an amplifier to cancel a common-mode voltage
common-mode voltage	A voltage that appears equally and in phase from each signal conductor with respect to ground. Also known as common-mode noise. Power noise induced from a power transformer is a typical example of this noise (voltage)
dead band	In static characteristics, the range through which an input signal can be varied without initiating an observable change in output signal
DI	Digital Input (contact & voltage level)
dielectric strength	The potential gradient at which electric failure or breakdown occurs
EMI	An abbreviation for Electromagnetic Interference. Impairment of a wanted electromagnetic signal due to an electromagnetic disturbance
error	Any discrepancy between a measured quantity, set-point, or rated value and the ideal value of the measured signal
hysteresis	An effect wherein a given value of a parameter may result in multiple values
input resistance	Resistance measured at the input terminals of an instrument under operating conditions
input source resistance	Resistance of the measuring circuit outside the instrument
ISO	An abbreviation for International Organization for Standardization
noise	An unwanted disturbance superimposed upon an indicated or supplied value, which obscures its information content
normal mode rejection ratio	The ability of certain amplifiers to cancel a normal mode noise, usually expressed in decibels
normal mode voltage	An unwanted input (noise) voltage superimposed on the measurement voltage
reference junction	That thermocouple junction which is at a known or reference temperature
reference junction compensation	A means of counteracting the effect of temperature variations of the reference junction, when allowed to vary within specified limits
reflash	Function to indicate repeating alarm occurrences among a group of alarms sharing the same output relay
resistance temperature detector	A detector for measuring temperatures with a change in electrical resistance that is a known function of temperature
resolution	The minimum detectable change of some variables in a measurement system, or a minimum change in supplied quantity that can be set
RS-422-A	The EIA (Electronics Industries Association) approved standard, which established the requirements for serial communications between computers

scaling	Recording of an input in terms of the engineering variable
shunt resistor	Resistor used at the input terminal to transfer a current into a voltage
step response	The behavior of a system when its input signal is zero before a certain time and is equal to a nonzero value after this time
thermocouple	A pair of dissimilar conductors joined at two points so that an electromotive force is developed by the thermoelectric effects when the junctions are different temperatures
TLOG	Time axis logging (MATH option)
TTL	An abbreviation for Transistor/Transistor Logic
VFD	Vacuum Fluorescent Display
warm-up time	The time (after power turn-on) required before its rated performance characteristics apply

INDEX

A

- A/D integration time 9 - 9
- abort SET UP settings 6 - 1, 9 - 2
- alarm
 - ACK key 4 - 3, 6 - 2
 - acknowledging 5 - 13
 - buffer 5 - 13
 - hysteresis 9 - 8
 - indicator 4 - 4
 - output relays
 - AND/OR type 9 - 3
 - energizing/de-energizing 9 - 4
 - HOLD/NON-HOLD 9 - 5
 - wiring 3 - 9
 - printout 1 - 3, 9 - 18
 - rate-of-change 7 - 10, 9 - 7
 - reflash function 9 - 2
 - sampling interval 9 - 7
 - setting 7 - 10
 - types 7 - 10
- ALM indicator 4 - 4
- auxiliary settings (AUX) 8 - 1

B

- bargraph
 - center-zero 4 - 4
 - left-referenced 4 - 4
 - selection of 9 - 20
- BAT indicator 4 - 4
- battery replacement 5 - 6
- boundary 8 - 5
- buffer
 - alarm 5 - 13
 - message 5 - 12
- burnout 9 - 10

C

- calibration 11 - 5
- carriage adjustment 11 - 4
- center-zero bargraph 4 - 4, 9 - 20
- characters which can be used 7 - 12
- chart
 - end 5 - 16
 - loading 5 - 2
 - part number 2 - 2
 - remaining length 11 - 1
 - replacing 5 - 2
- chart speed
 - 1 7 - 13
 - 2 8 - 10
 - for change-on-alarm 8 - 10
 - for remote control 8 - 10

- relation between printouts and 10 - 4, 7 - 13
- relation between printing interval of periodic printout and 7 - 13, 10 - 4
- setting 7 - 13

- CHT indicator 4 - 4
- cleaning the recorder 2 - 1
- clearing the alarm buffer 5 - 13
- clearing the message buffer 5 - 12
- clock setting 7 - 14
- color changing 9 - 15
- contact input 3 - 9, 7 - 5
- copy settings 7 - 15

D

- date and time
 - display 5 - 14
 - printout 1 - 2
 - setting 7 - 14
- de-energizing 9 - 4
- difference computation (DELTA) 7 - 6
- difference High/Low limit alarm 7 - 10
- digital input
 - contact 7 - 5
 - level 7 - 5
 - setting 7 - 5
 - wiring 3 - 6
- dimensions 3 - 3
- display
 - AUTO 5 - 14
 - CLOCK 5 - 14
 - MAN 5 - 14
 - selection of 5 - 14
 - VIEW 5 - 14

E

- energizing/de-energizing 9 - 4
- entering modes 6 - 1
- enter key 4 - 3, 6 - 2
- error messages 12 - 1
- external dimensions 3 - 3
- external RJC 9 - 11

F

- FAIL
 - how to cope with 5 - 16
 - wiring 3 - 10
- FEED
 - chart 5 - 7
 - key 4 - 3, 6 - 2
- flow chart
 - Operation mode 6 - 3
 - SET mode 6 - 4

SET UP mode 6 - 5
 fuse
 part number 2 - 2
 replacement 11 - 2

H

High/Low limit alarm 7 - 10
 HOLD/NON-HOLD
 alarm relay 5 - 13, 9 - 5
 indicator 5 - 13, 9 - 6
 hysteresis 9 - 8

I

I01 to I24 7 - 11, 9 - 3
 initialize 9 - 21
 initial values 6 - 7
 input
 filter 9 - 12
 range setting 7 - 1
 terminal 3 - 4
 type 1 - 3
 wiring 3 - 6
 internal RJC 9 - 11
 interval 9 - 19

K

key-lock
 part number 2 - 2
 setting 9 - 24
 usage 5 - 17
 keys 4 - 2, 4 - 3, 6 - 2

L

leaving modes 6 - 1
 left-referenced bargraph 4 - 4, 9 - 20
 list
 contents 5 - 8
 printout 5 - 8
 locking panel keys 5 - 17, 9 - 24
 Low limit alarm 7 - 10
 lubrication 11 - 7

M

maintenance 11 - 1
 MENU key 4 - 2, 6 - 2
 menus 6 - 3
 message
 buffer 5 - 12
 error 12 - 1
 printout 5 - 12
 setting 8 - 9
 modes
 entering and leaving 6 - 1
 operation mode 6 - 1
 SET mode 6 - 1
 SET UP mode 6 - 1

Index - 2

switching between 6 - 1
 mounting 3 - 2
 moving average 9 - 13

N

NON-HOLD
 alarm relay 5 - 13, 9 - 5
 indicator 5 - 13, 9 - 6

O

Operation mode 6 - 1
 option terminal block 3 - 4

P

panel
 cutout 3 - 3
 mounting 3 - 2
 partial expanded recording
 boundary 8 - 5
 setting 8 - 4
 pen
 adjustment 11 - 3
 change function 5 - 4
 loading 5 - 4
 part number 2 - 2
 plotter 5 - 5
 replacing 5 - 4
 periodic maintenance 11 - 1
 POC
 explanation 9 - 14
 indicator 4 - 4
 setting 9 - 14
 power
 supply specifications 10 - 7
 supply wiring 3 - 5
 switch 4 - 2, 5 - 1
 printing carriage adjustment 11 - 4
 printing interval 9 - 19
 PRINT key 4 - 2, 6 - 2
 printout
 alarm 1 - 2, 9 - 18
 channel numbers 1 - 2
 chart speed change 1 - 2, 9 - 17
 colors 1 - 2
 date and time 1 - 2, 9 - 17
 list 5 - 8
 manual 5 - 7
 message 5 - 12, 8 - 9
 periodic 1 - 2, 8 - 6, 9 - 18
 recording start 1 - 2, 9 - 17
 relation between chart speed and 10 - 4
 scales 1 - 2, 9 - 16
 SET UP list 5 - 10
 tag 1 - 2, 8 - 8, 9 - 16
 time tick 1 - 2

R
 range 7 - 1

rate-of-change High/Low alarm	7 - 10
RCD	
indicator	4 - 4
key	4 - 2
recording	
example	1 - 2
start/stop	5 - 7
start/stop trigger	9 - 23
reflash function	9 - 2
remote control	
chart speed	8 - 10
setting	9 - 22
wiring	3 - 11
removing	
battery	5 - 6
chart	5 - 2
felt-tip pen	5 - 4
fuse	11 - 2
packings	2 - 3
plotter pen	5 - 5
ribbon cassette	5 - 5
RJC	9 - 11
RTD	
range setting	7 - 4
types	7 - 4
wiring	3 - 7
S	
sampling interval	9 - 9
scaling (SCL)	7 - 7
SET indicator	4 - 4
SET Mode	6 - 1
setting	
alarms	7 - 10
analog recording	8 - 1
chart speed 1	7 - 13
chart speed 2	8 - 10
clock	7 - 14
DELTA	7 - 6
DI	7 - 5
digital printing	8 - 6
initial	6 - 7
initialize	9 - 21
input range	7 - 1
message	8 - 9
partial expanded	8 - 4
periodic printout	8 - 6
recording span	7 - 1
RTD	7 - 4
scaling (SCL)	7 - 7
SKIP	7 - 2
SQRT	7 - 8
tag	8 - 8
TC	7 - 4
units	7 - 12
VOLT	7 - 3
zone	8 - 2
SET UP list	
contents	5 - 10

printout	5 - 10
SET UP Mode	6 - 1
signal damping	9 - 12
spares	2 - 2
square root (SQRT)	7 - 8
starting	
before	2 - 1
list printout	5 - 8
manual printout	5 - 7
message printout	5 - 12
SET UP list printout	5 - 10
store SET UP settings	6 - 1, 9 - 2

T

tag	
printout	1 - 2, 9 - 16
setting	8 - 8
terminal block	
input	3 - 4
option	3 - 4
power supply	3 - 4
thermocouple input	
burnout	9 - 10
changing the temperature unit	9 - 21
range setting	7 - 4
RJC setting	9 - 11
types	7 - 4
wiring	3 - 7
time	
display	5 - 14
setting	7 - 14
trend recording	8 - 2
trigger	9 - 23

U

unit	
changing temperature	9 - 21
engineering	5 - 14
setting	7 - 12
unpacking	2 - 3

V

VIEW display	5 - 14
voltage level input	7 - 5

W

wiring	
alarm output	3 - 9
chart end	3 - 10
FAIL	3 - 10
input	3 - 6
power supply	3 - 5
remote control	3 - 11

Z

zone recording	8 - 3
----------------------	-------